

LuOcean M4 - Revision \geq 4.0

Diode Laser @ 670nm - 1940nm up to 830W

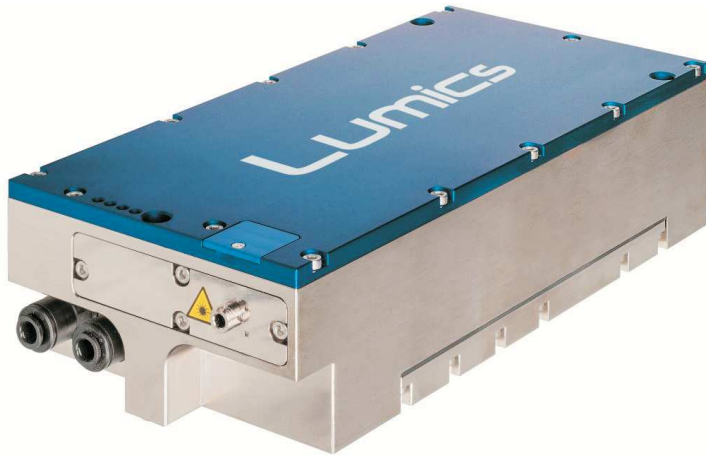

Description:

This LuOcean™ M4 Diode Laser offers an excellent product to manufacture state-of-the-art end user laser systems. The easy integration and safe use of these laser components give the chance to be cost-efficient in development and manufacturing. Equipped with several accessories and features the Lumics diode lasers comply with CE & ROHS requirements. Lumics warrants highest reliability single emitter technology through careful design, extensive burn-in, long lifetime & thermal testing.

Features & Functions:

- Up to three wavelengths
- 200 μ m - 1000 μ m NA 0.22 fiber
- Emitter electrically in series
- Temperature sensor
- Pilot intensity (voltage controlled)
- Water supply for fiber connector
- Humidity Sensor included

Options:

- Exchangeable protection window
- Red or green pilot
- Fiber sensor
- Power monitor
- OEM diode laser driver
- OEM water chiller
- FSMA or D80 connector
- Water cooling terminal for fiber connector

Benefits:

- Single emitter long lifetime
- Internal water cooling
- Sealed housing
- Small foot print

Applications:

- Therapeutic
- Dental
- Dermatology
- Veterinary

Module Drawing (Dimensions in mm)

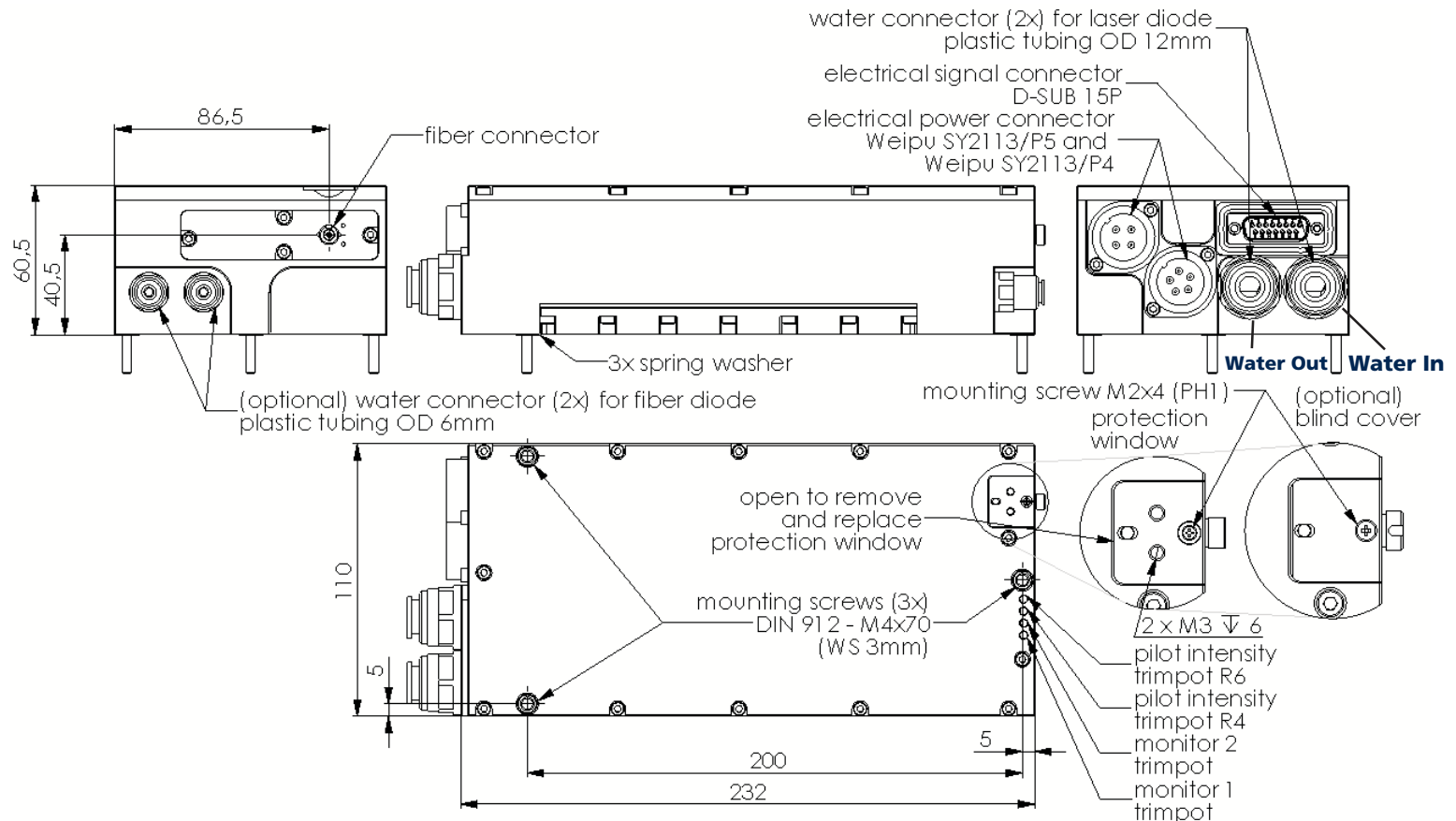

We manufacture diode lasers.

Terminal 2 Terminal 1

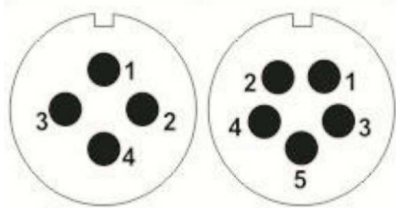

Connector - Laser Diode Supply

TM
 Weipu IP68 male connector on laser module (Part No. SY2113/P5/4).
 Counterpart (Part No. SY2113S5/4)
 Maximum current/voltage per pin is 30 A / 500V
 All laser diodes per wavelength group can be operated separately or electrically in series if the current is the same per group
Caution: Never operate the wavelength group electrically in parallel. This may damage the laser diodes.

Connector - Signals

IP68 male D-Sub connector on laser module
 Maximum current/voltage per pin is 3 A / 400V
 Counterpart standard 15 pol D-Sub female connector

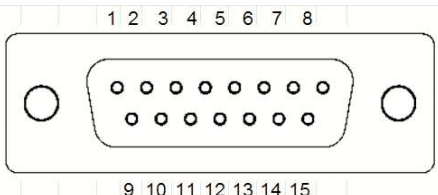
 1 2 3 4 5 6 7 8
9 10 11 12 13 14 15

Water Supply

Push-In connector, Housing material thermoplastic (Acetalcopolymer = POM-C)
 Laser diode cooling: thread to module 3/8" and water hose outer diameter 12mm
 Optional fiber cable cooling: thread to module 1/8" and water hose with outer diameter 6mm

T	Pin	Group	Configuration
1	1	1	Laser diode group 1 cathode (-)
1	2		n.c..
1	3	1	Laser diode group 1 anode (+)
1	4	2	Laser diode group 2 anode (+)*
1	5	2	Laser diode group 2 cathode (-)*
2	1	3	Laser diode group 3 cathode (-)*
2	2	3	Laser diode group 3 anode (+)*
2	3		n.c.
2	4		n.c.

T: Terminal

Group: diodes of group are electrically in series

Pin	Configuration
1	PT100 / NTC
2	PT100 / NTC 2 (*) or n.c.
3	PT100 / NTC 3 (*) or n.c.
4	Vcc (5 - 18V)
5	Fiber sensor 1 signal (*)
6	Fiber sensor 2 signal (*)
7	Monitor diode 1 signal (0V - 4V) (*)
8	Monitor diode 2 signal (0V - 4V) (*)
9	GND PT100 / NTC (*)
10	Vcc pilot laser 5V (red) 8V (green) (*)
11	GND pilot laser (*)
12	GND common
13	Pilot intensity control (0V - 5V) (*)
14	Humidity sensor out (0V - 4V) (*)
15	n.c.

* optional, n.c. means no connection

Electrical and Optical Characteristics / Typical Laser Specifications at 25° C *

Wavelength [nm]	Fiber Diameter	max. Power	Current [A] / Voltage per Group [V]	Fiber Types
670	400	68	6 / 2x32	**FSMA or D80 without cooling
760	1000	300	20 / 2x28	**D80 flange water cooled, fiber with end cap and AR
760 & 1064 (dual)	1000	170 & 220	20 / 1x28 & 24 / 1x25	**D80 flange water cooled, fiber with end cap and AR
785 or 808	200 (400)	160 (240)	8 / 2x28 (15 / 2x28)	**D80 flange water cooled, fiber with end cap and AR
975	200	Total 280	15 / 2x25	**FSMA or D80 water cooled, fiber with end cap and AR
940 & 980 (dual)	200	Total 330	15 / 2x25	**D80 water cooled, fiber with end cap and AR
940 & 980 (dual)	400	Total 470	25 / 2x25	**D80 water cooled, fiber with end cap and AR
940 & 980 & 1020 (triple)	400	Total 700	25 / 2x25	**D80 water cooled, fiber with end cap and AR
940 & 980 (dual)	600	Total 550	28 / 2x25	**D80 water cooled, fiber with end cap and AR
940 & 980 & 1020 (triple)	600	Total 830	28 / 2x25	**D80 water cooled, fiber with end cap and AR
975 & 1470 (dual)	400	100 & 100	25 / 25 & 21 / 1x20	**FSMA without cooling
1064	600	400	26 / 2x25	**D80 water cooled, fiber with end cap or AR
1470	200	100	14 / 2x20	**FSMA without cooling
1470	400	150	20 / 2x20	**FSMA without cooling
1940	200	33	7.5 / 2x16	**FSMA without cooling
1940	400	50	11 / 2x16	**FSMA without cooling
1470 & 1940 (dual)	400	70 & 23	20 / 20 & 11 / 16	**FSMA without cooling
1470 & 1940 (dual)	200	10 & 30	14 / 4 & 7.5 / 1x14,1x16	**FSMA without cooling

Notes: * taken at internal temperature sensor, Depending on the laser wavelength an AR <0.7% (+10nm around peak wavelength) coated fiber facet or end cap on fiber module side is required. Avoid direct feedback from materials like mirrors, optics, processed material etc. back into laser module via the fiber cable by more than 10%.

(1) Power is measured ex fiber according to given fiber specifications including measures and tolerances of fiber and ferrules for uncoated fiber facets (exception see *).

Minimum repeatable power with internal temperature and current accuracy of +0% is <=+-3% of maximum power. Please add tolerance of your temperature and current control.

(2) Do not exceed maximum forward current for rated power as given above by more than 5% otherwise the laser diode may be damaged

(3) Rule of thumb: Power ex fiber decreases by app. 12% (670nm), 5% (<1100nm), 7% (>1400nm) and 12% (>1900nm) every 10 °C temperature increase at internal temperature sensor. Lifetime decreases by about factor of two every 10 °C. Required flatness of customer heat sink 0.05mm over entire bottom surface to achieve necessary contact to the heat sink.

(4) Red and green minimum pilot power is set at factory by customer request. Standard is 3/0.5 mW.

(5) Adjust trimpot R6 to set maximum intensity with pin 10 control left open or set to 0.5V

(6) Adjust trimpot R4 to set intensity off with pin 10 control set to 5V

(7) Calculation of the thermal load and necessary thermal resistance of a heat sink to maintain internal diode temperature of 25°C :

Thermal load = Output power * (1/conversion efficiency - 1)

Heat sink thermal resistance = (25 °C - ambient temperature) / thermal load

General Parameters / Accessories

Parameter	Symbol	Min	Typ	Max	Unit
Storage Temperature	T _S	-10		55	°C
Internal operating * and (Ambient) temp , c.w.-operation **	T _{Op c.w.}	10(5)		35(40)	°C
Humidity / Non-condensing Atmosphere				90	%
Maximum fiber flange temperature				50	°C
Weight			2.5		kg
Compliance			CE, ROHS		

Further Options (Please ask for quotation if needed)

Optical fiber patchcord, Laser diode drivers for each individual wavelength, Interface cable , OEM laser diode driver and temperature controller

* taken at internal temperature sensor ** we recommend to operate the laser above dew point. Below dew point water condensation on the exit window may damage the window when laser is switched on. If the module was stored below dew point before operation dry the window by pre-heating the module to 25°C

We manufacture diode lasers.

Electrical and Optical Characteristics Typical laser specifications at 25° C *

Parameter	Conditions	Symbol	Min	Typical	Max	Unit
Conversion Efficiency	depending on wavelength		40% (7/8xxnm), 45% (9/10xxnm), 25/15% (14/19xxnm)			%
Spectral Shift with Temp. <1100nm		I_{T_shift}		0.3		nm / K
Spectral Shift with Temp. 14xxnm		I_{T_shift}		0.7		nm / K
Spectral Shift with Temp. 19xxnm		I_{T_shift}		1		nm / K
Fiber Centricity				<10		μm
Numerical Aperture		NA		0.22		
Fiber Connector Type				FSMA or D80		
Humidity Sensor - always included no option (4)				<0.9	1.6	V
Pilot Beam (Option)						
Pilot Beam Output Power	red/green - adjustable		0	1/0.5	3/1	mW
Pilot Beam Wavelength	red/green		640 / 510	650 / 520	660 / 530	nm
Pilot Beam Operating Voltage	red/green		4/7		5/8	V
Pilot Beam Operating Current	red/green				<35/200	mA
Pilot Beam Intensity Control Voltage	red/green		0(max. Intensity)		5(min. Intensity)	V
Sensors (Options)						
Power Monitor Signal Voltage (2)			0		4	V
Fiber Detection Sensor Signal Voltage			<0.2 (unplugged)		>4 (plugged)	V
Temperature Sensor			Standard NTC (10k) or optional (PT100 or LM35)			

Cooling

Required water temperature (water quality see (5))	c.w.	TW	15		<=23	°C
Required water flux at TW	c.w.		scales with power level			l/min
Thermal resistance x water flux	c.w.			0.06		K/W l/min
Proportional coefficient between pressure drop and flow rate		Fp		0.13		bar/l x min
Inlet pressure		p			3.5	bar

(4) Sensor signal range from (0.5-4)V and signal voltage depends linearly on humidity. 1.1V means app. 9% rel. Humidity and 4V means 100% rel. humidity. Voltage must be kept below 1.6V for safe operation. Humidity (%RH) calculates from signal voltage by (signal voltage-0.82V)/(0.032V/%RH). Above 2.2V signal the diode laser may be damaged must not be turned on.

(5) You must use colourless, free of oil and grease purified or double purified water (2 MΩmxcM > resistivity >20 kΩmxcM, pH between 6-8, hardness <10dH or <200ppm CaCO3, particle diameter <200μm)

Calculation example of thermal load and necessary water flow to maintain temperature difference of 10K between water and internal temperature sensor. Required water temperature and flow depends on maximum thermal load and maximum internal temperature. Thermal load is calculated as follows:

Thermal load = Output power * (1/conversion efficiency - 1), Thermal resistance = temperature difference of water to internal sensor / thermal load

Water flow = Thermal resistance x water flux / Thermal resistance

Example: Output power: 440 W at 9xxnm, Conversion efficiency: 0.45, Thermal load = 440 W * (1/0.45 - 1) ~ 540 W and water flow = 0.06 K/W * l/min / 10 K * 340W = 3.3l/min

Fiber Connector

- (1) Lumics laser diode fiber coupling technology ensures specified loss into the fiber cladding depending on the fiber core centricity, ferrule diameter and distance of the fiber end facet to the reference plane compliant with the shown technical drawing of the fiber connector
- (2) Free standing fibers suffer from higher risk of fiber damage to the fiber tip due to mechanical stress by handling and the fiber end facet can not be polished as simple as for not free standing fibers.
- (3) Please study the fiber data sheet http://www.lumics.de/wp-content/uploads/lu_fiber_patchcords.pdf and the fiber manual before operation.

D80 Fiber Connector with Key

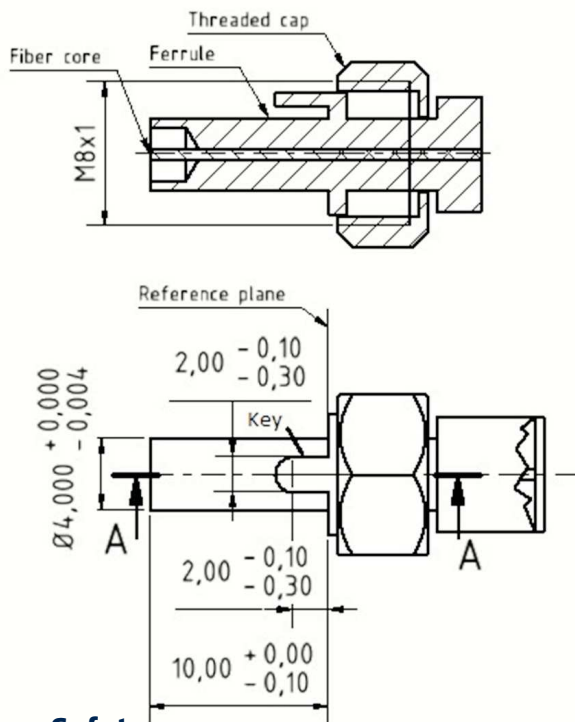

F-SMA Fiber Connector without Key

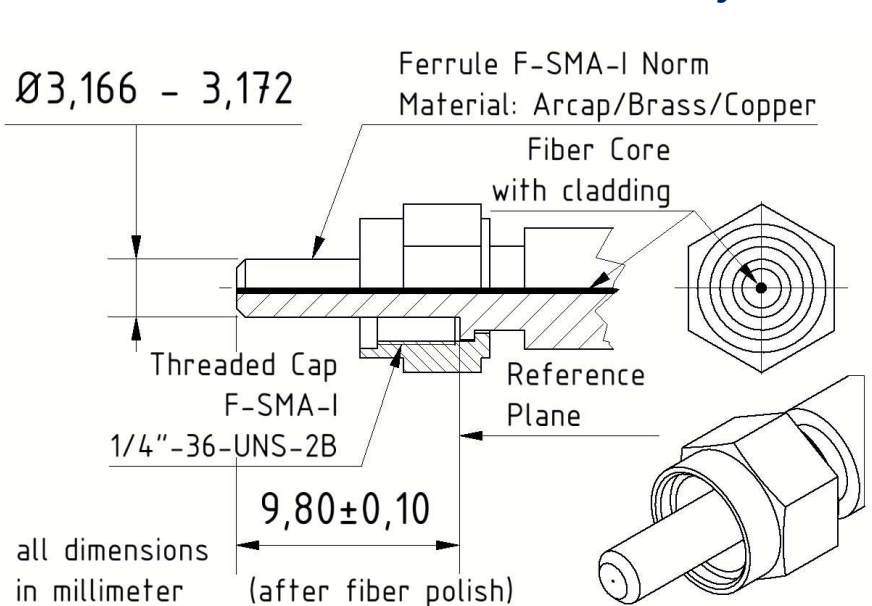

User Safety

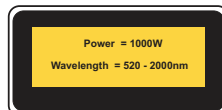
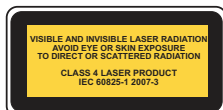

Important Note Read and carefully follow operating manual instructions. Especially, whenever power supply is switched on or off, always disconnect from laser module. See manual for details. Uncontrolled on / off switching may cause spikes and result in fatal device damage. This product is not certified by with IEC 60825-1 or 21CFR1040.10/ 21CFR1040.11 and must comply with the applicable regulations by the Purchaser if sold as laser product.

We manufacture diode lasers.