

AirGuard

Portable Breathing Air Filtration System
15 CFM, 1 Airline Connection



PRODUCT HIGHLIGHTS

- Meets OSHA Grade D breathing air requirements
- CO and differential dew point sensors
- Removes oils, solid particles, water and unpleasant odors
- Respirator CFM and sensor flow alarms
- Visual and audible alarm warnings
- Datalog - OSHA compliance records
- Portable - battery operated, rechargeable

AirGuard is an innovative next-generation solution for OSHA Grade D compressed breathing air requirements. It integrates breathing air filtration with sensors for Carbon monoxide (CO) and differential dew point for both safety and breathing air comfort.

Designed with the user in mind, AirGuard has an external easy-to-read display to communicate threats beyond general audible alarm warnings. The display is readable from over 30 feet allowing for a quick response when AirGuard detects a hazardous situation.

Using its menu-driven interface, AirGuard is easy to operate. It provides a system status upon power up and most importantly keeps track of the sensor and function status and calibration interval. The AirGuard data log records all the real-time sensor data,

calibration events, and diagnostic data over time. This data is easily downloadable to a PC using the removable USB drive for operational record keeping and OSHA compliance reporting.

The AirGuard model AGP-15-1 has a 15 CFM capacity with 1 output connection for NIOSH approved supplied-air respirators. It can be configured to use either Hansen or Schrader standard connections allowing ease of compatibility with breathing air accessories. AirGuard has a state of the art three-stage air filtration system that removes oils, water, solid particles, and unpleasant odors.

AirGuard

GENERAL SPECIFICATIONS

Display:	Backlit, 7" diagonal color display
Alarms:	User programmable
Air Flow Alarm Pt:	< 5 CFM \pm 1 CFM
Sensor Types:	Carbon Monoxide (0 to 50 ppm) Dew Point (-20°F to ambient)
Sensor Accuracy:	Carbon Monoxide: \pm 5% @ 10 ppm Dew Point: \pm 2°F @ 50°F
Sensor Response Time:	<60 seconds
Keypad:	3-button touch, weatherproof w/tactile feedback
Battery Life:	10 hours before recharge
Data Logging:	2 points per minute
Data Storage Medium:	USB memory stick
Fittings:	Hansen or Schrader Connections
Inlet Pressure:	Maximum 150 psi
Total Air Capacity:	Maximum 15 CFM
Outlet Connection:	Supplied with one coupling
Inlet Port:	1/2 inch quick disconnect
Filter Train:	3-stages of filtration (5 micron, 0.01 micron, carbon adsorber)
Weight:	19.2 Lbs.
Warranty:	2 years on sensors and monitor (excluding replacement filters)
Agency Approval:	UL 61010 U.S. and Canada
Optional Models Available:	30 CFM Two Couplings 50 CFM Four Couplings 100 CFM Eight Couplings

DIMENSIONS

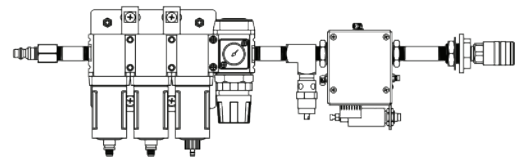
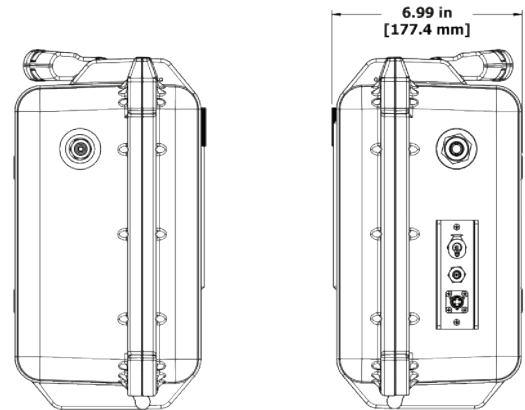
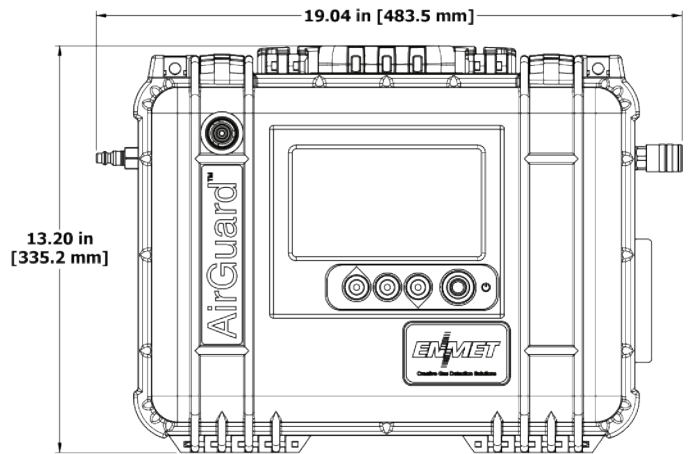

AirGuard 15 CFM 1-port airline connection

ORDERING INFORMATION

Description

AirGuard - Portable, 15 CFM, One Coupling Hansen Type, CO and Differential Dew Point Sensors
AirGuard - Portable, 15 CFM, One Coupling Schrader Type, CO and Differential Dew Point Sensors
Calibration Kit Assembly, AirGuard
AirGuard Replacement Filter Kit 15 CFM

Part No.

AGP-15-1-00-00
AGP-15-1-00-01
03414-005
73089-100