

# PIglide FPC: Flat Pad Circular Air Bearings

FRICTIONLESS MODULAR AIR BEARINGS



## A-41X Series

- Diameters from 25 mm to 300 mm
- Payload to 1590 kg (3500 lbs)
- Stiffness to 860 kN/mm
- Mounting hardware, customizations, and accessories available
- For construction of positioning, scanning, metrology, inspection & calibration systems

### Overview

PI's line of flat pad circular air bearings is designed for use in any application where frictionless, accurate linear or planar motion is required. The modular nature of these bearings allows the user to build their own motion system. Multiple bearings can be combined to increase load capacity or to create multi-axis motion platforms. Air bearings are wear-free and ideal for clean environments. Air bearings do not exhibit any breakaway or running friction, regardless of payload.

Part#	Diameter (mm)	Ball Interface Diameter (mm)	Load Capacity (N [lbf])	Stiffness (N/ $\mu$ m [lbf/ $\mu$ in])	Air Flow (L/hr [SCFH])	Mass (g [oz])
A-411.025	25	13	88 [20]	17.5 [0.10]	60 [2]	16 [0.6]
A-411.040	40	13	220 [50]	28.0 [0.16]	60 [2]	42 [1.5]
A-411.050	50	13	330 [75]	52.5 [0.30]	85 [3]	66 [2.3]
A-411.065	65	13	660 [150]	78.8 [0.45]	115 [4]	171 [6.0]
A-411.080	80	13	1010 [230]	111 [0.64]	170 [6]	259 [9.1]
A-411.100	100	20	1710 [390]	175 [1.00]	170 [6]	505 [18]
A-411.125	125	20	2780 [625]	254 [1.45]	230 [8]	1105 [39]
A-411.150	150	20	4000 [900]	350 [2.00]	285 [10]	1590 [56]
A-411.200	200	20	7700 [1750]	520 [2.97]	570 [20]	4040 [143]
A-411.300	300	20	15500 [3500]	860 [4.90]	850 [30]	12000 [423]

Note: Values assume supply pressure of 550 kPa (80 psi). Contact PI for specifications if alternate supply pressures are needed.

Guideway Surface Flatness	< 1 $\mu$ m / 300mm (0.00005" / 12")
Guideway Material	Guideways are customer-supplied. Granite, hardcoat aluminum, stainless steel, ceramics, nickel-plated steel, or nickel-plated cast iron are recommended guideway materials.
Nominal Fly-Height	10 - 15 $\mu$ m (0.0004" - 0.0006")
Operating Pressure	80 psi (550 kPa) nominal
Air Quality	Clean (filtered to 1.0 $\mu$ m or better) - ISO 8573-1 Class 1 Oil-free -ISO 8573-1 Class 1 Dry (-15 °C dew point) - ISO 8573-1 Class 3
Construction	Hardcoat Aluminum / SS Fasteners
Bearing Type	Discrete Orifice

### Mounting Hardware (sold separately)

Part #	Description	Ball Interface Diameter (mm)
A-412.013S	Threaded Ball Stud Assembly	13
A-412.013N	Mounting Nut	13
A-412.013P	Retaining Plate	13
A-412.020S	Threaded Ball Stud Assembly	20
A-412.020N	Mounting Nut	20
A-412.020P	Retaining Plate	20

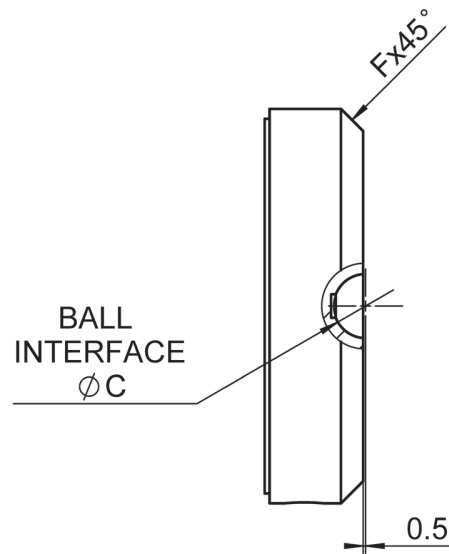
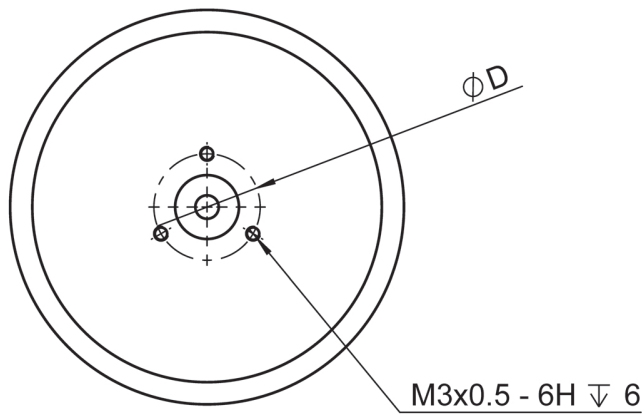
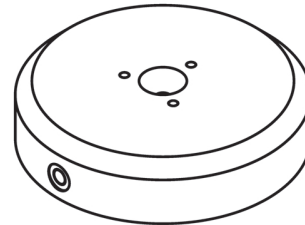
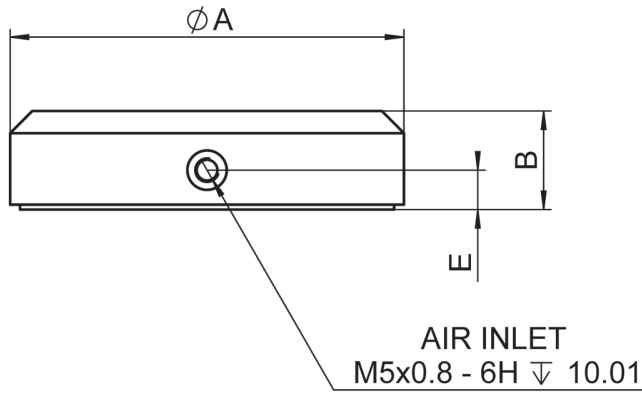

Model	A	B	C	D	E	F
A-411.025	25	13	13	N/A	6.4	1.5
A-411.040	40	13	13	21.6	7	1
A-411.050	50	13	13	21.6	7	1
A-411.065	65	20	13	21.6	8	1
A-411.080	80	20	13	21.6	8	4.5
A-411.100	100	25	20	31.6	9	6.4
A-411.125	125	35	20	31.6	9	6.4
A-411.150	150	35	20	31.6	9	6.4
A-411.200	200	66	20	31.6	9	25
A-411.300	300	66	20	31.6	9	25

## Mounting Hardware Dimensions: 13mm diameter ball interface

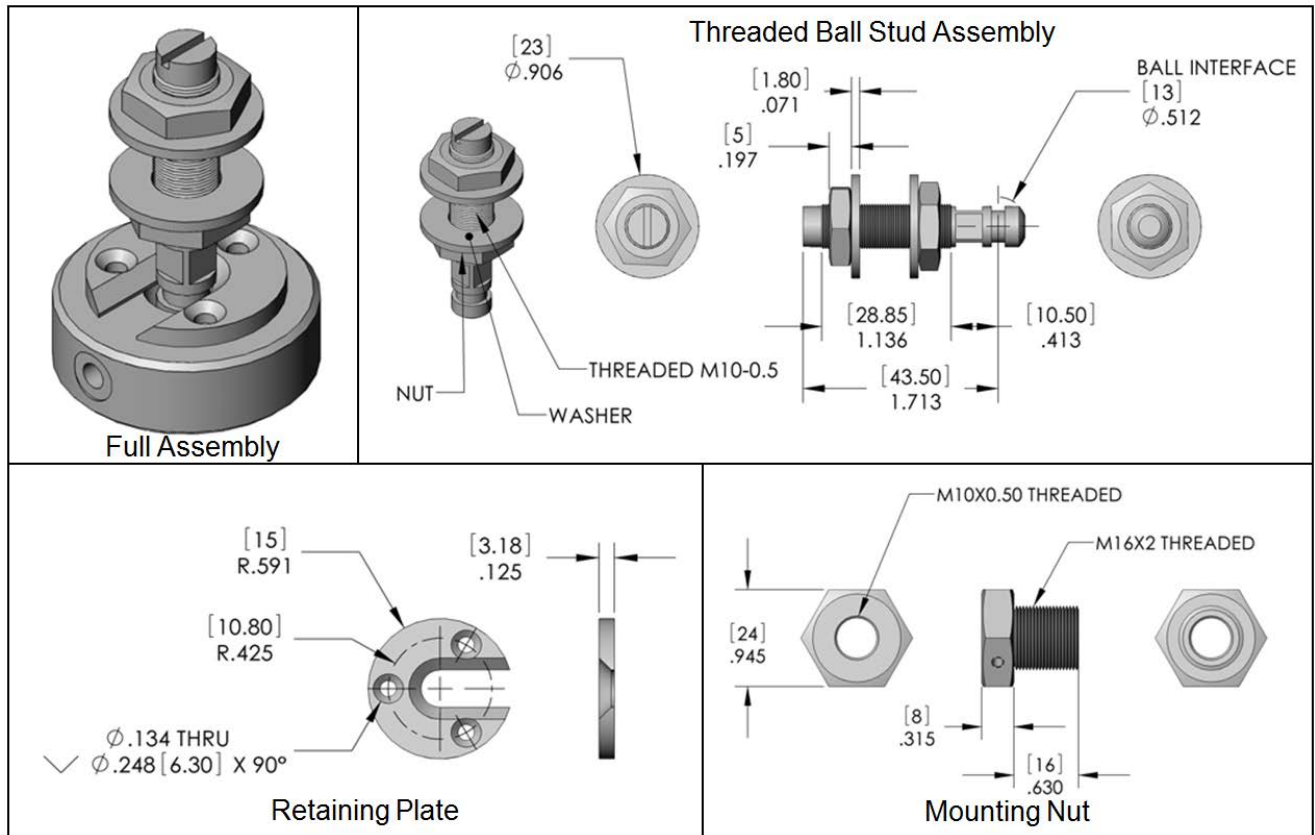

## Mounting Hardware Dimensions: 20mm diameter ball interface

