

SDH/SONET 155Mbps Transceiver TV1xxxx(STM-1/OC-3)



- 1.3µm or 1.55µm SMF Transceiver
 - SDH STM-1, SONET OC-3
- Data Rate of 155Mbps
- Single +3.3V or 5V Power Supply
 - 1X9 Duplex SC Connector

Family Model

TV13315	TV13340	TV15380	TV153A0	TV153C0
TV13515	TV13540	TV15580	TV155A0	TV155C0

Features

- Compliant with SONET OC-3 and ITU-T SDH STM-1 specifications
- Industry standard 1X9 package with duplex SC connector
- 1.3µm or 1.55µm uncooled InGaAsP SMQW Fabry-Perot(FP) LD or distributed feedback(DFB) LD and APC for constant output power
- High sensitive InGaAs PIN photodiode used at wavelengths from 1.1µm to 1.6µm
- Single +3.3V or +5V power supply
- LVPECL differential data inputs and outputs
- Operating temperature ; 0 to +70°C/-40 to +85°C
- Tested by Teradian's Reliability and Qualification Program
- Distance options
15km/40km/80km/100km/120km with 9/125µm SMF

Description

The TV1xxxx series transceivers are designed to meet the specifications of SONET OC-3 and ITU-T SDH rates of STM-1(155.52Mbps). The transceivers are manufactured in 1x9 pin package with duplex SC connector interface and made of plastic or metallized housing to obtain excellent EMI shielding.

The OSA is driven by a custom IC which converts differential LVPECL logic signals into a laser diode drive current. The receiver includes a planar InGaAs PIN photodiode mounted with a transimpedance preamplifier IC in an OSA. The OSA is mated to a custom limiting-amplifier which provides post-amplification and signal detect function(active high).

The transceivers are designed to used in a single power supply(+3.3V or +5V) and an operating temperature range of 0°C to +70°C or -40°C to +85°C.

Applications

Used in telecommunication and data communication systems, from medium to high speed for intra-office, short-haul inter-office and long-haul inter-office applications.

- Intra-office and Inter-office SONET/ITU-T SDH
- Fiber in the loop(FTTO, FTTC, FTTH etc.)
- Subscriber loops
- High-speed data links, Single-mode FDDI
- Private optical networks
- ATM

Absolute Maximum Ratings

Parameters	Symbol	Unit	Min.	Max.	Remarks
Ambient Operating Temperature 15km ~ 80km	T_{op}	°C	0	70	Indoor use
			-40	85	Outdoor use
			0	70	Indoor use
100km ~ 120km					
Storage Temperature	T_{stg}	°C	-40	85	
Supply Voltage	$V_{CC}-V_{EE}$	V	-0.5	6.0	
Lead Soldering Temperature/Time		°C/sec		260/10	
Relative Humidity	RH	%	-	95	

Electrical Characteristics

Parameters			Symbol	Unit	Min.	Typ.	Max.	Remarks
DC Power Supply Voltage			$V_{CC}-V_{EE}$	V	3.1 4.75	3.3 5	3.5 5.25	3.3V 5V
DC Power Supply Current			$I_{CC,TX}$	mA	35		140	5V option
			$I_{CC,RX}$	mA	95		115	
Input Data Voltage	Low		$V_{IL}-V_{CC}$	V	-1.810		-1.475	3.3V/5V
	High		$V_{IH}-V_{CC}$	V	-1.165		-0.880	
Output Data Voltage	Low		$V_{OL}-V_{CC}$	V	-1.892		-1.548	3.3V/5V
	High		$V_{OH}-V_{CC}$	V	-1.051		-0.879	
SD Output Voltage	PECL option	Low	$V_{SD, Low}$	V	-		-1.48	3.3V/5V
		High	$V_{SD, High}$	V	-1.16		-	
	TTL option	Low	$V_{SD, Low}$	V	-		-2.50	3.3V Only
		High	$V_{SD, High}$	V	-1.10		-	

Eye Diagram

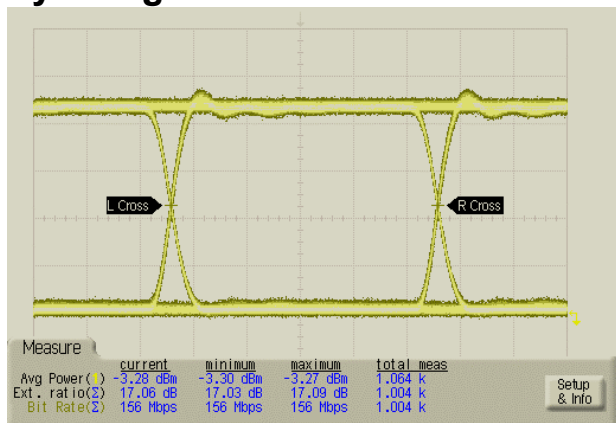

Fig. 1 Back-to-back

Optical Characteristics

(T_{op} = 25°C)

Parameters	Symbol	Condition	Unit	Min.	Typ.	Max.	Remark
Data Bit Rate		PRBS 2 ²³ -1,NRZ	Mbps		155.52		
Fiber Length 9μm core SMF		10 ⁻¹⁰ BER, 155Mbps	km	15		40 120	1.3μm FP 1.55μm DFB
TRANSMITTER							
Average Power Output	P _{OUT}	I _f =I _{BIAS} + I _{mod} /2	dBm	-15 -5 -2 +1	-10 -3 0	-8 0 +2 +3	15km 40/80km 100km 120km
Extinction Ratio	ER		dB	10			
Center Wavelength	λ _c	CW, @ P _{OUT}	nm	1261 1270 1480	1310 1310 1550	1360 1360 1580	15km 40km 80-120km
Spectral Width	Δλ	RMS Width Max. -20dB WD	nm		2.5 2.5	4.0 3.0 1.0	15km 40km 80-120km
Side Mode Suppression Ratio	SMSR		dB	30			80-120km
Optical Rise/Fall Time	t _r /t _f	10 - 90%	nsec			2.0	
RECEIVER							
Sensitivity (Average Input Power)	P _{IN,MIN}	PRBS 2 ²³ -1, 10 ⁻¹⁰ BER	dBm		-37 -37	-34 -36 -38	15-80km 100km 120km
Receiver Overload	P _{IN,MAX}		dBm	-3.0			
Signal Detect Threshold Decreasing light input Increasing light input	P _D P _A		dBm dBm	-46		-38	
Signal Detect Hysteresis	P _A - P _D		dB	0.5	1.0		

Pin Descriptions

Pin No.	Symbol	Description	Level/Logic
1	V _{EER}	Rx Ground	Power supply
2	RD+	Rx Data out(+)	PECL
3	RD-	Rx Data out(-)	PECL
4	SD	Rx Signal detect. (HIGH level for normal operation)	PECL output
5	V _{CCR}	Rx Power supply	Power supply
6	V _{CCT}	Tx Power supply	Power supply
7	TD-	Tx Data in(-)	PECL
8	TD+	Tx Data in(+)	PECL
9	V _{EET}	Tx Ground	Power supply

Recommended Interface Circuit

The transceiver can operate with PECL logic level. The interface circuit with direct-coupled PECL interface is shown in Figure 1. When interfacing with non-PECL logic level, AC coupling can be used as shown in Figure 2. The Signal Detect circuit monitors the incoming optical signal and generates a logic LOW signal when the optical signal is lower than a predefined level. The power supply filters are required for good EMI performance and should be as close to the transceiver as possible.

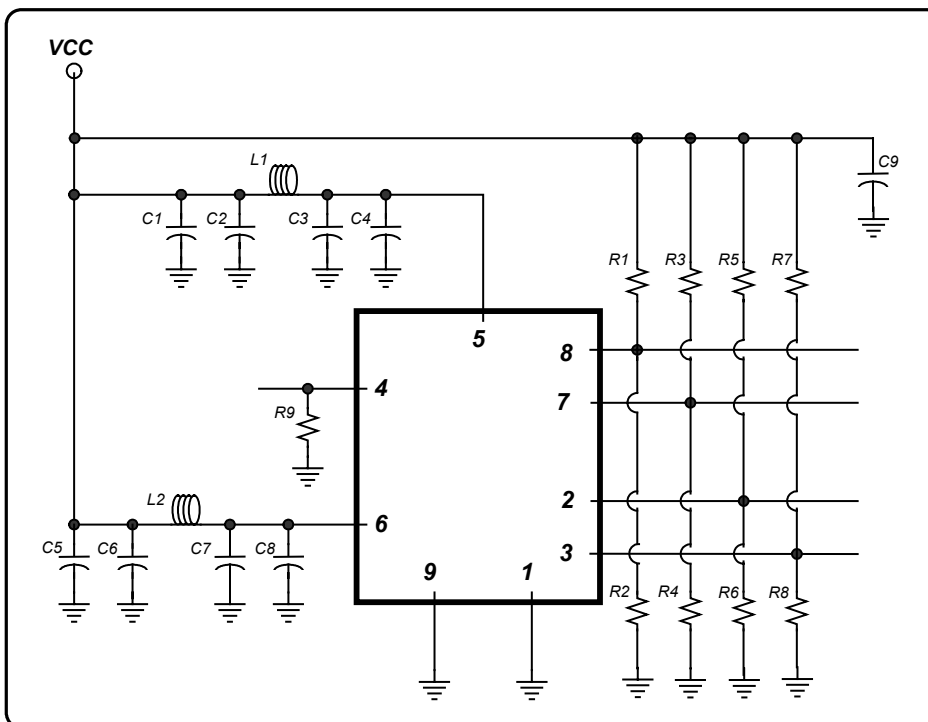

C1=C4=C5=C8=10uF,
C2=C3=C6=C7=0.1uF,
C9=0.1uF

L1=L2=1.0uH or
Ferrite inductor

R1=R3=R5=R7=82Ω
(5.0V) or 82Ω (3.3V),
R2=R4=R6=R8=130Ω
(5.0V) or 130Ω (3.3V),
R9=510Ω(5.0V) or
142Ω (3.3V)

Fig. 2 DC-Coupled PECL Interface

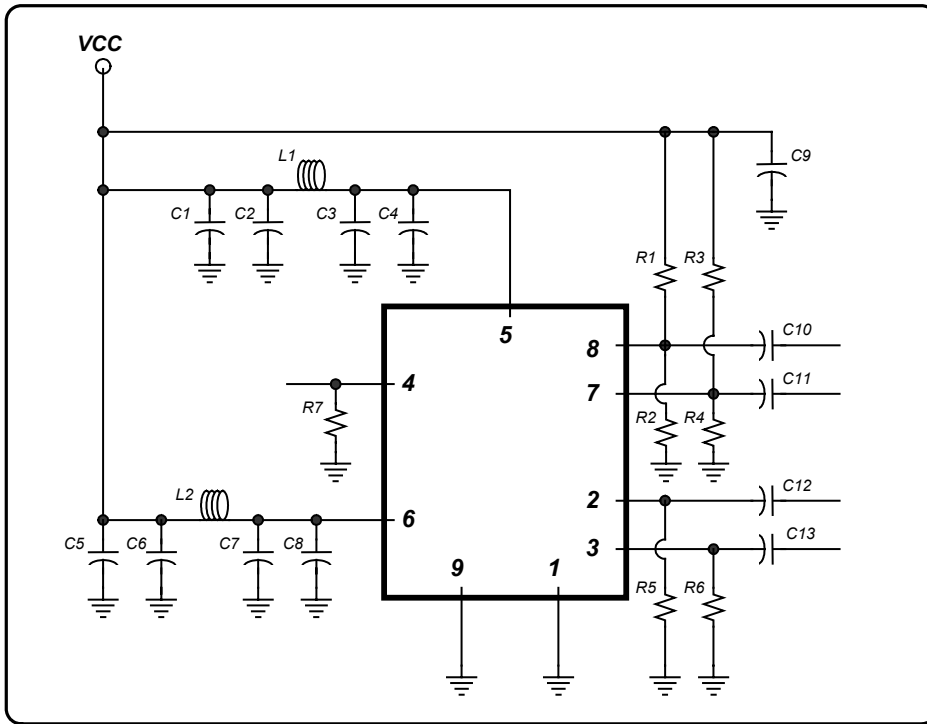

$C1=C4=C5=C8=10\mu F$,
 $C2=C3=C6=C7=0.1\mu F$,
 $C9=0.1\mu F$, $R1=R3=68\Omega$
 (5.0V) or 82Ω (3.3V),
 $R2=R4=180\Omega$ (5.0V)
 130Ω (3.3V),
 $R5=R6=270\Omega$ (5.0V)
 or 142Ω (3.3V),
 $R7=510\Omega$ (5.0V)
 Or 270Ω (3.3V),
 $C10=C11=C12=C13$
 $=0.1\mu F$,
 $L1=L2=1.0\mu H$
 or Ferrite inductor

Figure 3. AC-Coupled PECL Interface.

Outline Diagram

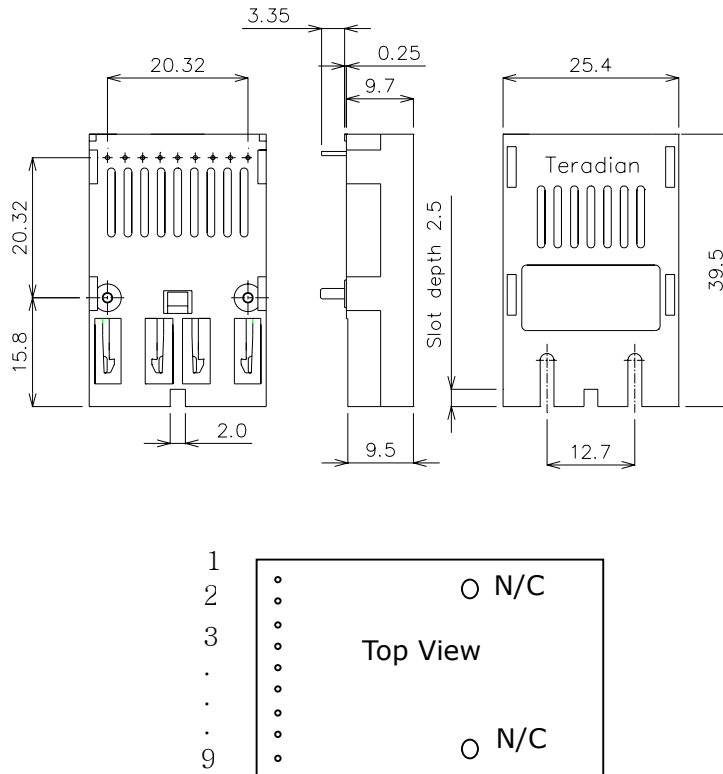

Fig.4 SC duplex Transceiver Package Dimensions [unit: mm]

! Handling Caution

The transceiver can be damaged by overvoltage and current surges. Precautions should be taken for transient power supply.

This device is susceptible to damage as a result of electrostatic discharge(ESD). Take proper precautions during both handling and testing

! Caution

- All adjustments are made at the factory before shipment to our customers. No maintenance and alteration to device is required.
- Tampering with or modifying the performance of the modules will result in voided product warranty. It may also result in improper operation of the circuitry, and possible overstress of the semiconductor components. Device degradation or product failure may result.
- Use of controls or adjustments or procedures other than those specified herein (ex : Connection of the modules to a non-approved optical source, operating above the recommended absolute maximum conditions, operating in a manner inconsistent with unit design and function) may result in hazardous radiation exposure and may be considered an act of modifying or manufacturing a laser product. The person(s) performing such an act is required by law to recertify the laser product under the provisions of US 21CFR (Subchapter J).
- The use of optical instruments with this product will increase eye hazard.

Notice

On operation, If optical connectors are unterminated, modules can emit invisible laser radiation. Avoided eye exposure to direct or indirect radiation

Ordering Information

Com pany	Func- tion	Data Rate	Wavelength	Supply Voltage	Distance	Pin	Temp. Range	Shielding
T	V	1	3	3	15	9	I	N
Ter- a- dian	V ;TRV S ;SFF F ;SFP B ;Bi-Di TRV. (Recep- tacle) D ;Bi-Di TRV. (Pig- tailed)	1 ;155Mbps 4 ;622Mbps F ;1.06Gbps 8 ;1.25Gbps S ;2.12Gbps G ;2.5Gbps A ;Asy. Bi-Di 622M/155M E ;Asy. Bi-Di 1.25G/155M O ;Order- made	3 ;1.3μm 5 ;1.55μm 6 ;Bi-Di T1.3/R1.5 7 ;Bi-Di T1.5/R1.3 8 ;850nm A ;1470nm B ;1490nm C ;1510nm D ;1530nm E ;1550nm F ;1570nm G ;1590nm H ;1610nm M ;1270nm N ;1290nm O ;1310nm P ;1330nm Q ;1350nm R ;1370nm S ;1390nm T ;1410nm U ;1430nm W ;1450nm	3 ;3.3V 5 ;5V	SX ;Note1 02 ;2km LX ;5km 10 ;10km 15 ;15km 20 ;20km 30 ;30km 40 ;40km 60 ;60km 80 ;80km A0 ;100km C0 ;120km	1 ;2X5 (10 pin) 2 ;2X10 (20 pin) 9 ;1X9 (9 pin)	I ;Indoor Use (0~70℃) O ;Outdoor Use (-40~85℃)	N ;No Shield M ;Metal coating

*Note 1 ;

- 220m with 62.5/125μm MMF @1.25Gbps
- 500m with 50/125μm MMF @1.25Gbps
- 200m with 62.5/125μm MMF @2.125Gbps

*Note 2 ; additional order information

- Connector type default is SC/PC and the default length of fiber is 1m
- In case of ordering pigtailed Bi-Di Transceiver, please specify specs. clearly if not default.

More Information

Teradian Inc.

Address 946, Dunsan-dong, Seo-gu, Daejeon, 302-120, Korea
 Tel +82-42-476-4800, 4803(Oversea Sales Team)
 Fax +82-42-476-4805
 Homepage <http://www.teradian.com>
 e-mail sales@teradian.com