



MPY-RS Pyroelectric Detector



Description

MPY-RS is a fast and compact pyroelectric detector for sensitive radiation measurements from the UV to THz range. Due to its extended electronic bandwidth it can be used without a chopper for sources with up to 5kHz repetition rate.

Physical Properties

Detection principle	Pyroelectric
Detector material	Black coated LiTaO ₃
Weight	80 g
Operating Temperature	-20 °C - 50 °C
Dimensions (H x B x T)	59.8 mm x 45.3 mm x 21.0 mm
Detector window dimensions	(5,0 x 5,0) mm ²
Active detector area	(3,0 x 3,0) mm ²
Thread of detector cap	SM05 (compatible to Thorlabs components)

Electrical Properties

Power supply	±12 V Linear low noise power supply (Thorlabs LDS12B)
Power socket	3-pole, M8
Output socket	SMA
Output signal	Analog
Output signal level	-8 V - 8 V

Measuring Properties

Voltage responsivity	25 000 V/W ($\lambda = 1.5 \mu\text{m}$); $f = 500 \text{ Hz}$
Response time (0-100%)	typ. 200 ms (corresponds to thermal time constant)
Frequency range	5 Hz - 5 kHz *
Noise equivalent power (NEP)	750 pW/ $\sqrt{\text{Hz}}$ ($\lambda = 1.5 \mu\text{m}$, $f = 20 \text{ Hz}$, 20 °C)
Noise density	21 $\mu\text{V}/\sqrt{\text{Hz}}$ (<i>rms</i> , $f = 20 \text{ Hz}$, $BW = 1 \text{ Hz}$, 20 °C)
Detectivity	typ. $4 \times 10^8 \text{ cm}\sqrt{\text{Hz}}/\text{W}$
Maximum measurable power	500 μW ($f = 500 \text{ Hz}$, Si window)
Damage threshold (max. avg. power density)	60 mW/cm ²
Spectral bandwidth	UV - THz (real bandwidth depends on the window used)
• KBr-window	$\lambda = 200 \text{ nm} - 30 \mu\text{m}$
• Si-window	$\lambda = 1 \mu\text{m} - 1000 \mu\text{m}$
• Teflon-window	$\lambda = 60 \mu\text{m} - 1000 \mu\text{m}$
• Without window	$\lambda = 10 \text{ nm} - 1000 \mu\text{m}$

Further window materials on request.

* Detector only sees signal changes – a chopper is required for CW applications!

Geometric Dimensions

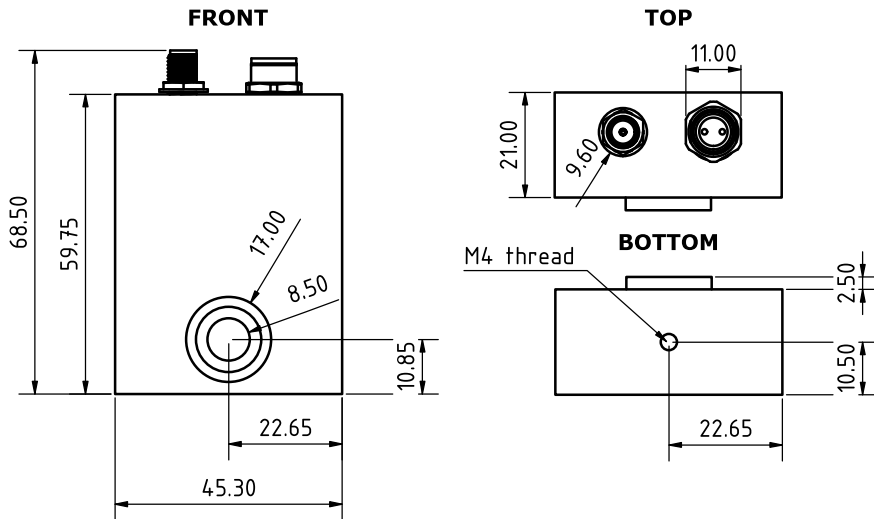

Typical Performance

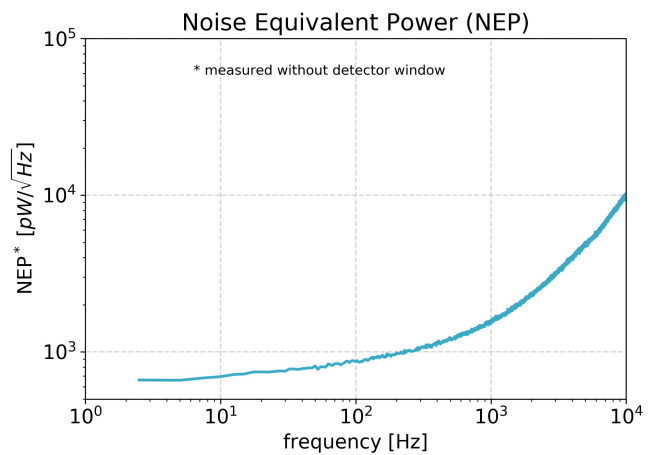
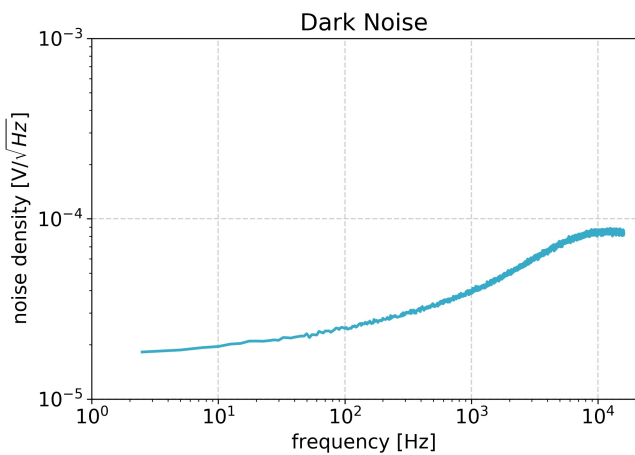
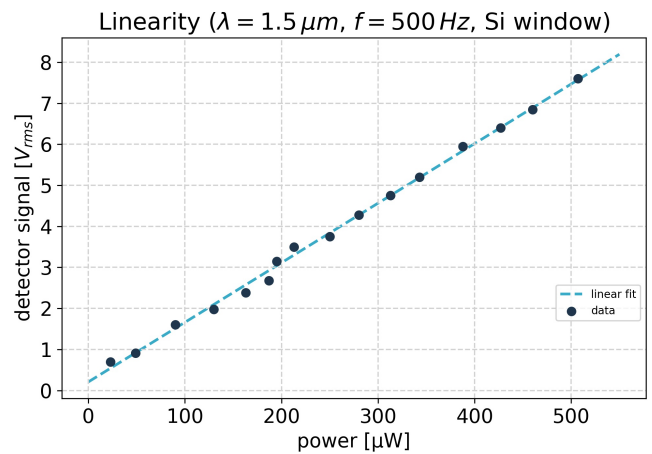
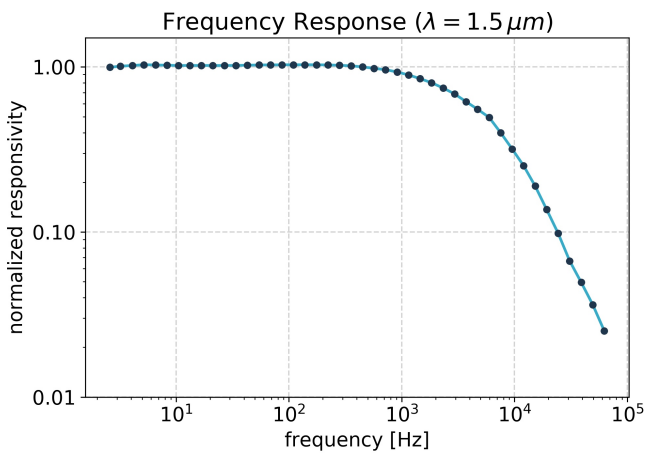

Rev. 1.4

Information in this document is subject to change without notice.

Copyright © WiredSense GmbH, 2022. All rights reserved.

WiredSense GmbH

Luruper Hauptstr. 1

22547 Hamburg

Germany

www.wiredsense.com