



Applications

- Signature Recognition
 - Biologicals
 - Chemicals
- Molecular Spectroscopy
- Solid State Spectroscopy
- THz Imaging
- Materials Characterization
- THz CW Generation & Detection

Features

- Rugged package design with all welded construction
- Polarization maintaining fiber coupled
- Internal lens for optimal performance
- Hi resistivity hyper-hemisphere for low loss coupling to free-space
- Integrated 30 V zener diodes for ESD protection
- Angled interfaces for high return loss
- Operation at 780 nm to 855 nm
- Custom configurations available

Terahertz Photomixers

The PB1319 family of terahertz photomixers provide the proven high performance of Low Temperature Grown Gallium Arsenide semi-conductor technology in a practical, rugged, fiber-coupled package. These photomixers are built to ISO:9000 manufacturing standards and employ fully laser welded assemblies with an integrated optical lens for the pump lasers as well as a THz Silicon lens. The PB1319 photomixers have a proven record of reliability even down to temperatures of 4.5 Kelvin.

PB1319 photomixers are commonly employed in coherent photomixing systems for both the production and detection of terahertz radiation. They are available in several configurations as well as in custom mounts or configurations and are laser welded assemblies with an integrated optical lens as well as a collimating THz Silicon lens.

Product Specifications (Standard Photomixer)

Parameter	Min	Typical	Max	Units
Operating Case Temperature*	-40	25	+85	°C
Operating Optical Wavelength	760	-	855	nm
Effective THz Spectrum	100	-	3000	GHz
Dark Current @ 20 V Bias, 25°C	-	0.3	.5	μA
Bias Voltage on Transmitter	-	±20	±25	V
THz Power @ 200 GHz**	.02	0.1	0.5	μW
THz Power Dynamic Range @ 100 GHz ***	-	70	-	dB
THz Power Dynamic Range @ 1000 GHz ***	-	50	-	dB
Average Optical Pump Power	-	30	40	mW
Optical Return Loss @ 780 nm	20	40	-	dB

Product Specifications (Low Temperature Photomixer)

Parameter	Min	Typical	Max	Units
Operating Case Temperature*	4.5	300	350	K
Operating Optical Wavelength	760	-	785	nm
Effective THz Spectrum	100	-	3000	GHz
Dark Current @ 20 V Bias, 25°C	-	0.3	.5	μA
Bias Voltage on Transmitter	-	±20	±25	V
THz Power @ 200 GHz**	.02	0.1	0.5	μW
THz Power Dynamic Range @ 100 GHz ***	-	70	-	dB
THz Power Dynamic Range @ 1000 GHz ***	-	50	-	dB
Average Optical Pump Power	-	30	40	mW
Optical Return Loss @ 780 nm	20	40	-	dB

* Non-condensing atmosphere

** Pumped with 30 mW @ 780 nm and biased to 500 uA photocurrent

*** In a photomixing system like the PB7200 and dependent upon laser source

Typical Configuration

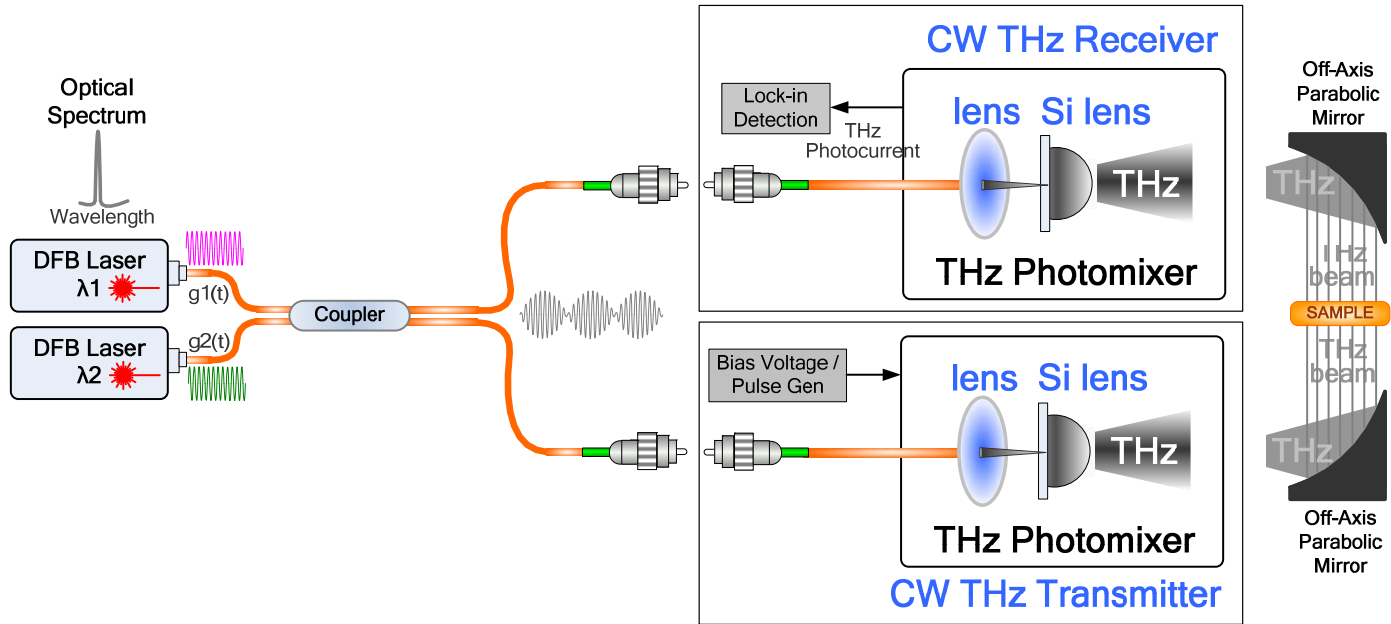

Typical Performance

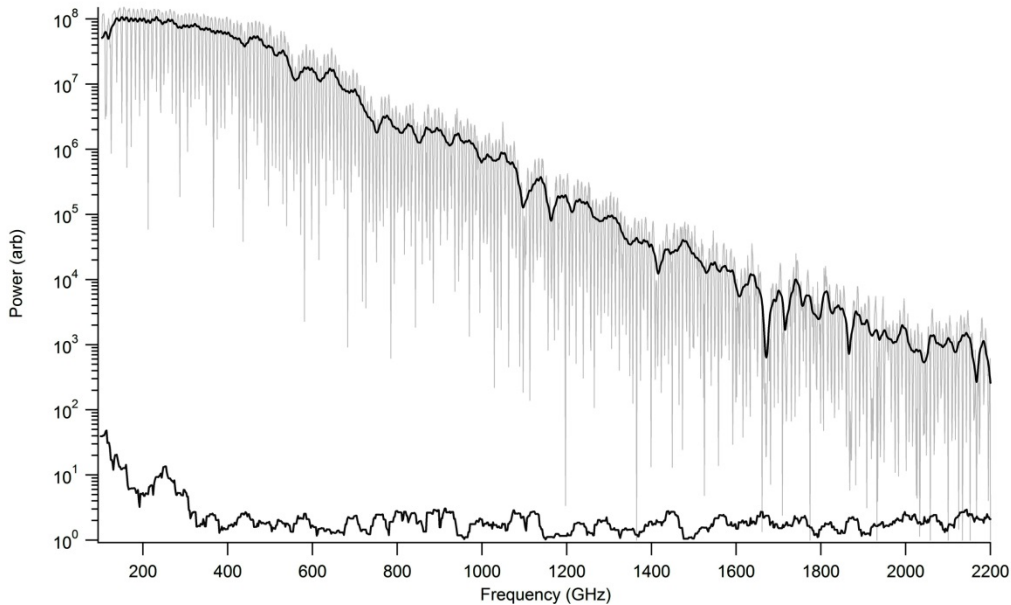

Typical performance when two photomixers are employed as in a PB7220 Series spectrometer. The noise level power illustrated by blocking the THz beam is due to the lasers. Higher spectral purity lasers will improve the dynamic range. The interference fringe due to the coherent detection is in grey and has been smoothed away.

Mechanical Dimensions

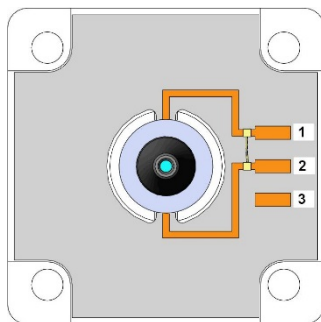
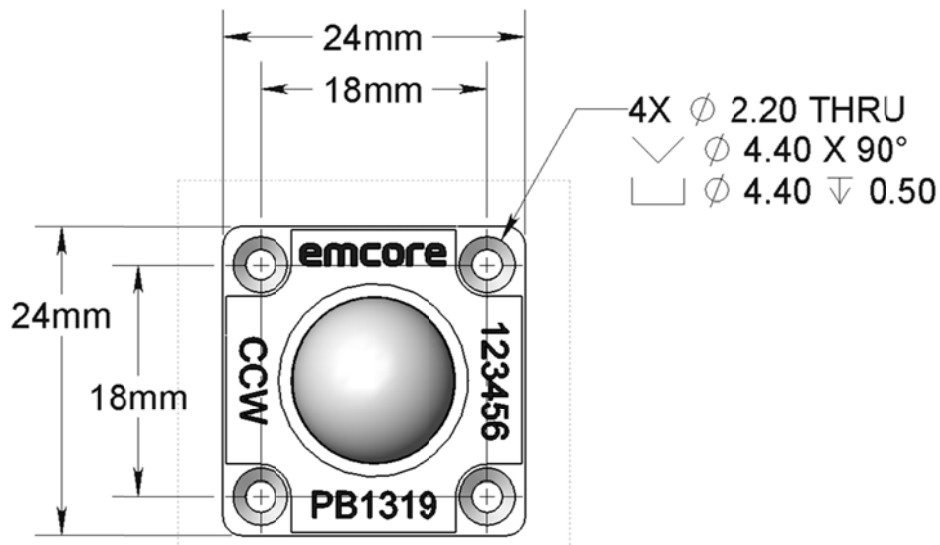
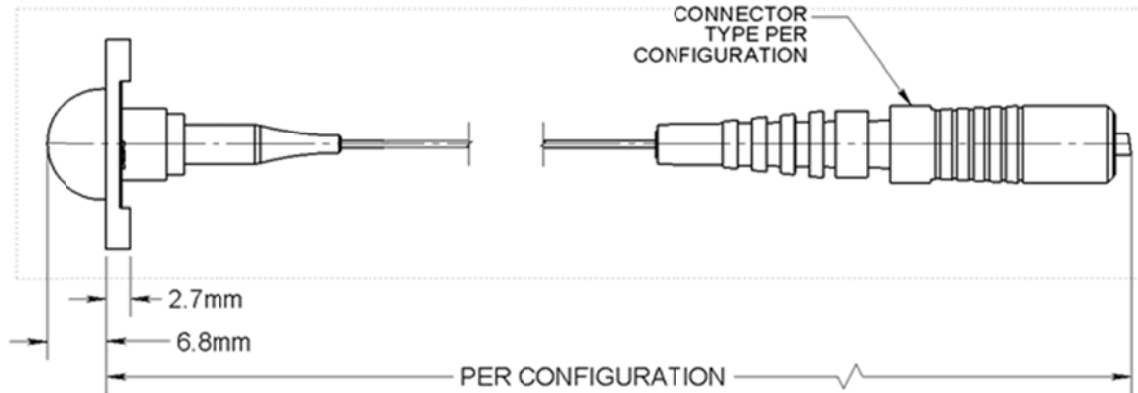

Pin	Description
1	Bias Lead 1
2	Bias Lead 2
3	Case GND

Notes:

- Terminals are ESD protected with back-to-back 30V Zener diodes
- Maximum emitter bias of 25 volts (Zeners will prevent higher bias)
- Zeners may be disconnected for higher bias but will void warranty

Ordering Information – Model Number Options

PB1319-ST-CCW-SC/APC-1.15/900

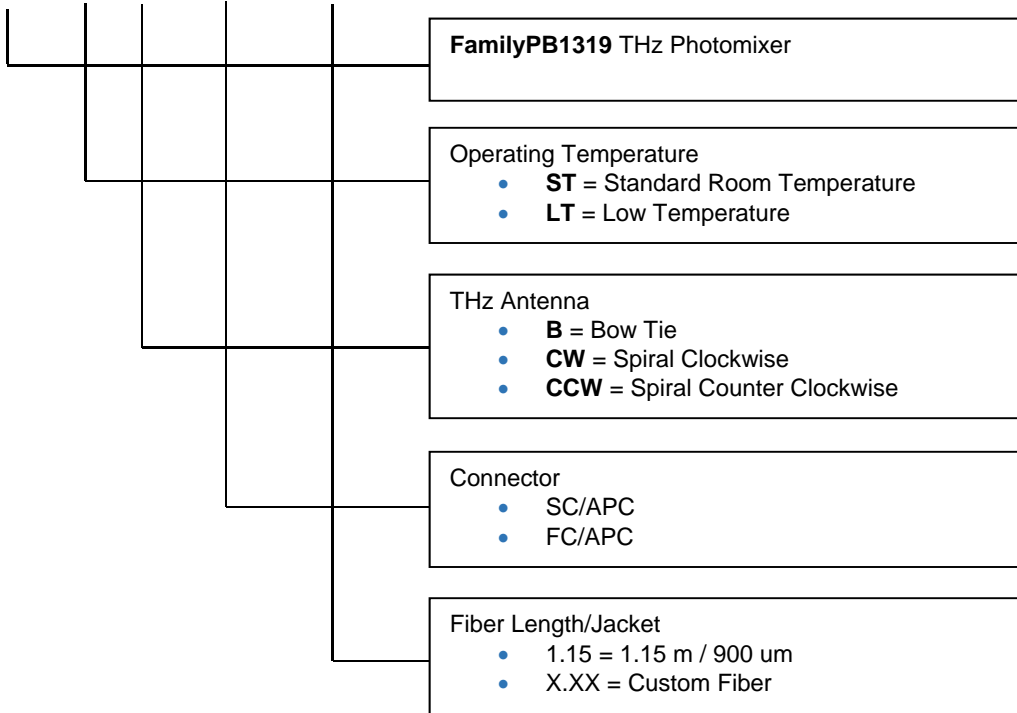

Contact Information

Dr. Joseph R. Demers
E: joseph.demers@bakmantechologies.com
P: +1 626-993-0305
M: +1 626-676-6175
www.bakmantechologies.com