

# Air-cooled SUB-Nanosecond Laser

The SUB50A-700 laser DATASHEET, March 2023



## Air-cooled SUB-NANOSECOND E-O Q-SWITCHED LASER

The **SUB50A-700** model is an **air-cooled** Electro-Optically Q-switched DPSS **1064 nm** laser delivering up to **50 mJ** energy and **700 ps** pulse duration at **20 Hz** repetition rate. Laser design is based on short laser cavity direct pumping MO and power amplifiers with the **VCSEL pump** technology. The know-how on thermo-stabilized structure fixed MO and AMPL elements gives extremely stable output parameters performance. **Small laser form-factor** and unique **≤200 ps optical jitter** is welcome point for integration into OEM. Due to relatively high pulse energy, good  **$M^2 \leq 1.3$**  parameter and short sub-ns pulse duration, laser delivers **up to 71 MW** peak power. An optional conversion module to green (532 nm) and ultraviolet (355 nm, 266 nm) is

available.

## Typical Laser Specifications<sup>\*)</sup>

Model	SUB50A-700
Wavelength <sup>1)</sup>	1064 nm
Pulse energy	up to 50 mJ
Typical pulse duration <sup>2)</sup>	~ 700 ps
Pulse to pulse energy stability <sup>3)</sup>	< 1 % RMS
Power drift <sup>4)</sup>	± 3.0 %
Pulse repetition rate <sup>5)</sup>	20 Hz
Beam profile	Near Gaussian
$M^2$	≤1.3
Beam divergence <sup>6)</sup>	< 1 mrad
Polarization	Linear, vertical
Spectral linewidth	SLM
Beam pointing stability <sup>7)</sup>	≤ 100 μrad
Typical beam diameter <sup>8)</sup>	~5 mm
Optical jitter <sup>9)</sup>	≤ 200 ps RMS
Dimensions (preliminary)	
Laser head (W×L×H)	167 × 478×232 mm
Controller unit (W×L×H)	470 × 445 × 165 mm
Beam height	133 mm
Operating requirements	
Cooling requirements	Air cooled
Ambient temperature	15 – 25 °C
Relative humidity (non-condensing)	10 – 80 %
Mains voltage <sup>10)</sup>	230 VAC, single phase, 50-60 Hz
Power consumption	< 450 W

\*) Typical specifications are illustrative; they are indications of typical performance and will vary with each unit we manufacture. Due to continuous improvements all specifications are subject to change. Unless stated otherwise all specifications are measured at 1064nm.

- 1) Other wavelengths may be also available on request
- 2) FWHM level at 1064 nm. Other pulse duration is available by request. Please inquire for detailed specifications.
- 3) Averaged from 60 seconds time interval.
- 4) Over 5-hour period after max 5 minutes of warm-up when ambient temperature variation is less than ±2°C.
- 5) Factory-set pulse repetition rate is fixed at max repetition rate.
- 6) Full angle measured at the 1/e<sup>2</sup> level.
- 7) RMS value measured from 60 seconds time interval.
- 8) Beam diameter is measured at 20 cm distance from laser output at the 1/e<sup>2</sup> level.
- 9) In respect to external Q-switch triggering rising edge pulse.
- 10) Laser can be powered from appropriate different mains on request. Inquire for details.

Geola Digital UAB  
Naugarduko 41, LT-03227,  
Vilnius, Lithuania, EU

Phone: +370 521 32737  
Email: [info@geola.com](mailto:info@geola.com)  
[www.geola.com](http://www.geola.com)

# Air-cooled SUB-Nanosecond Laser

The SUB50A-700 laser DATASHEET, March 2023



## Application

- LIBS (Light Induced Breakdown Spectroscopy)
- Mass Spectroscopy (Time of flight mass spectrometry)
- LIF (Light Induced Fluorescence)
- LIDAR (Light Detection and Ranging)
- Material processing
- Remote Sensing

## Dimensions SUB50A-700

Laser head

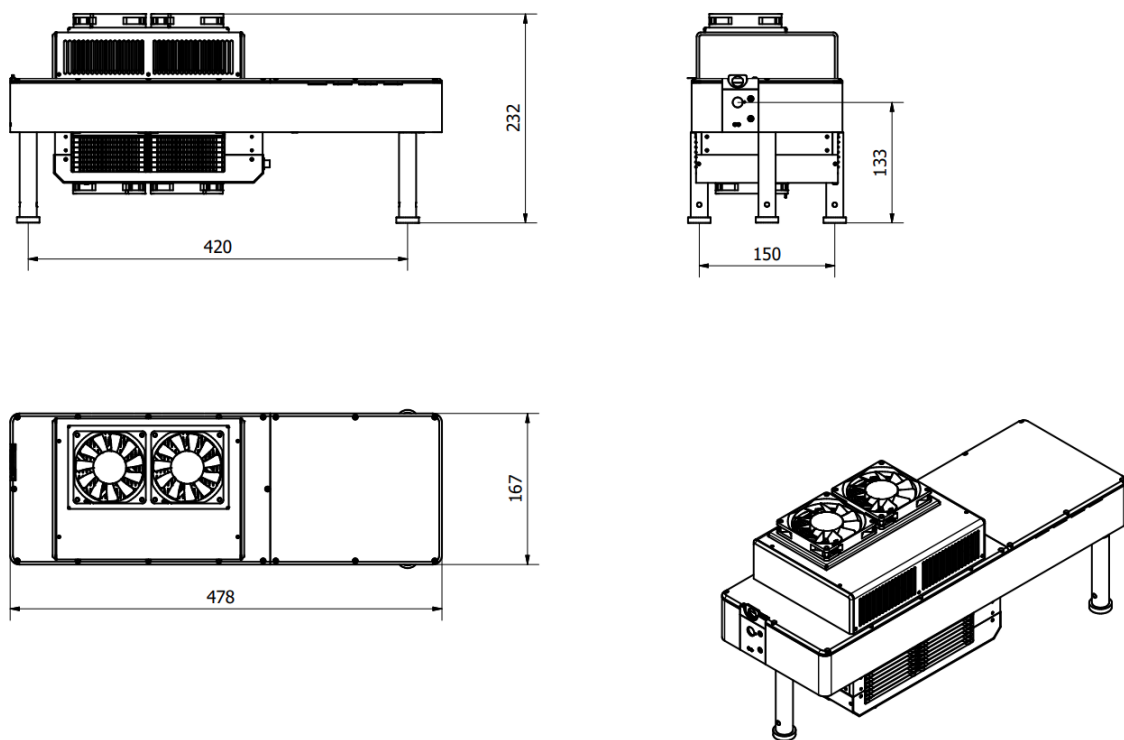

Laser controller

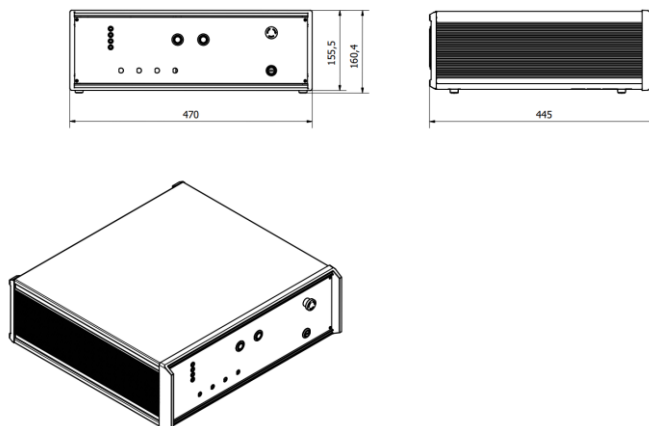

Geola Digital UAB  
Naugarduko 41, LT-03227,  
Vilnius, Lithuania, EU

Phone: +370 521 32737  
Email: [info@geola.com](mailto:info@geola.com)  
[www.geola.com](http://www.geola.com)

# Air-cooled SUB-Nanosecond Laser

The SUB50A-700 laser DATASHEET, March 2023



## Laser Beam Profile at beam waist plane



**BEAMAGE-3.0**

Monday, February 27, 2023

**gentec-eo**  
PARTNERS for ACCURACY

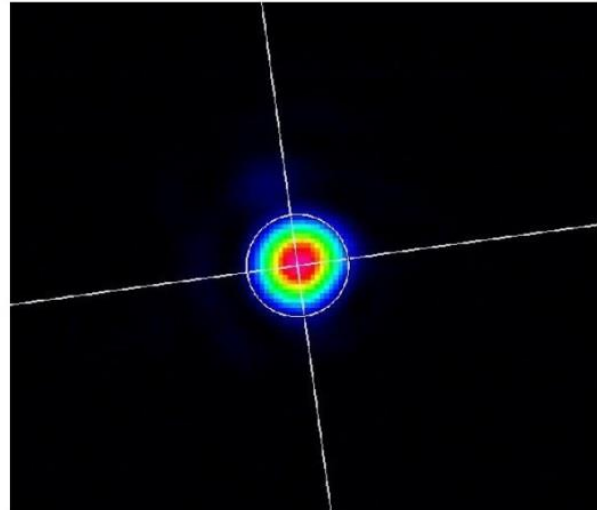
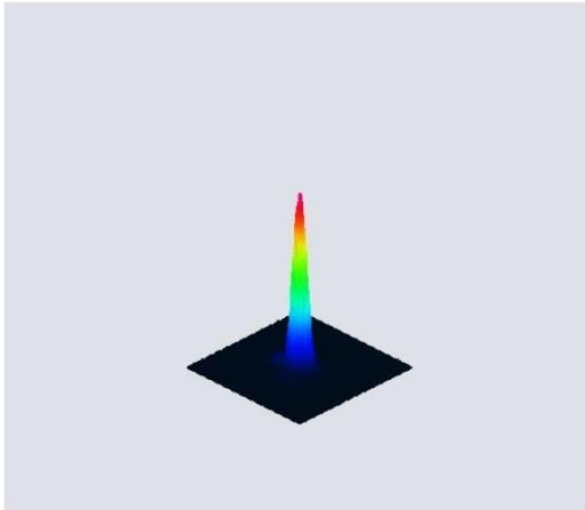

## Beam waist plane image

$$M^2_{x,y}=1.3$$

Focal length of BK7 plano-convex lens  $f=323$  mm.

Distance from the Principal Image Plane of the lens to the image plane  $S=340.7$  mm.

### PARAMETERS

Beam Diameter : 1/e2 along crosshair (13.5%)
Crosshair Center: Centroid
Orientation Crosshair: Auto Orient
Exposure Time: 50.00 ms (MANUAL)
Image Orientation: 0 degrees
Image Averaging: None
Active Area: 128 x 128
Pixel Addressing: None
Camera Gain: 1.00
ADC Level: 12 bit
Relative Position (X,Y): (0.0,0.0) $\mu\text{m}$

### MEASURES

Axis (dSigma X, dSigma Y): (122.1,122.1) $\mu\text{m}$
Effective Diameter: NA
Ellipticity: 100.0 %
Orientation: 7.8 degrees
Centroid (X,Y): (-9.7,-10.6) $\mu\text{m}$
Peak (X,Y): (-16.5,-5.5) $\mu\text{m}$
Peak Saturation Level: 78.4 %
Peak to Average Ratio (X,Y): (1.5,1.6)
Divergence (X,Y):
Relative Centroid (X,Y): (-9.7,-10.6) $\mu\text{m}$
Relative Peak (X,Y): (-16.5,-5.5) $\mu\text{m}$

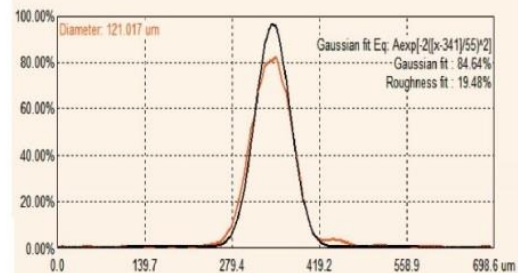
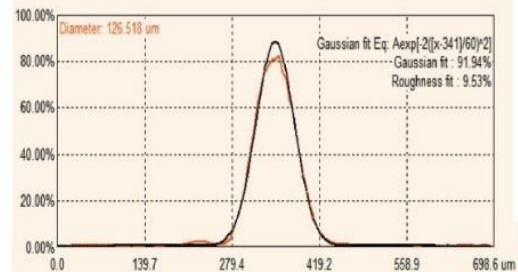

Geola Digital UAB  
Naugarduko 41, LT-03227,  
Vilnius, Lithuania, EU

Phone: +370 521 32737

Email: [info@geola.com](mailto:info@geola.com)

[www.geola.com](http://www.geola.com)