

The data should be read in conjunction with the Magnetron Preamble.

ABRIDGED DATA

Fast tuned pulse magnetron for linear accelerators. The tuning drive will rapidly tune the tube to any point in the frequency range and has been designed to be driven remotely by a DC power supply (see note 1).

Tuning range (see note 2)	-	10 MHz
Peak output power (nominal)	-	5.0 MW
Magnet and launching section	-	Separate electromagnet and launching section assembly MG6030
Isolator (see note 3)	-	Use of an isolator is recommended
Output	-	No. 10 waveguide (72.14 x 34.04 mm internal)
Cooling	-	Water and forced-air, or water and SF ₆

GENERAL DATA

Electrical

Cathode	-	Indirectly heated
Heater voltage (see note 4)	-	13 V
Heater current	-	14 A
Heater starting current, peak value, not to be exceeded	-	40 A max
Cathode pre-heating time (minimum)	-	6.0 minute
Tuner current (see note 5)	-	± 5 A max
Tuner coil impedance:		
At 0 A	-	6.8 Ω
At 5 A (with cooling, see note 6)	-	8.0 Ω



Mechanical

Overall dimensions	-	See outline
Net weight	-	8 kg approx.
Mounting position	-	Any

Accessories

Electromagnet/launching section	-	MG6030
Sidarm radiation absorber	-	MG6016
1 μF coaxial capacitor (see note 4)	-	MA997A

Whilst e2v technologies has taken care to ensure the accuracy of the information contained herein it accepts no responsibility for the consequences of any use thereof and also reserves the right to change the specification of goods without notice. e2v technologies accepts no liability beyond the set out in its standard conditions of sale in respect of infringement of third party patents arising from the use of tubes or other devices in accordance with information contained herein.

Cooling

The magnetron anode and the electromagnet have integral water jackets.

The magnetron requires a water flow of 18 to 27 litres/minute; the pressure drop across the water jacket is 103 kPa maximum.

The electromagnet requires a water flow of 4.5 litres/minute at a pressure drop of 14 kPa.

The magnetron output window may be cooled by either high pressure air or an arc suppressant gas such as SF₆. When the output window is cooled by high pressure air, a flow of not less than 0.085 m³/minute (NTP) into the air inlet at the base of the launching section is required. If SF₆ is used, then no gas flow is required to cool the window. See note 7.

Low pressure air cooling may be required for the cathode terminal.

MAXIMUM AND MINIMUM RATINGS (Absolute values)

These ratings cannot necessarily be used simultaneously, and no individual rating must be exceeded.

	Min	Max	
Magnetic field (see note 8)	120	164	mT
Heater voltage (see note 4)	12.0	13.5	V
Anode voltage (peak)	34	55	kV
Anode current (peak):			
At 5.0 MW, 3.0 μs, 158 mT	-	265	A
At 2.5 MW, 5.0 μs, 153 mT	-	160	A
At 1.0 MW, 5.0 μs, 135 mT	-	100	A
Input power (peak) (see note 9)	-	14	MW
Input power (mean) see note 10)	-	7.0	kW
Duty cycle	-	0.003	
Tuner current	-	±5	A
Tuning range	1.0	1.4	MHz/A
Pulse duration:			
At 5.0 MW peak	-	3.0	μs
At 2.5 MW peak	-	5.0	μs
At 1.0 MW peak	-	5.5	μs
Rate of rise of voltage pulse (see note 11)	100	150	kV/μs
VSWR at the output coupler (see note 3)	-	1.3:1	
Anode water outlet temperature	-	70	°C
Pressurising of waveguide (see note 7)	-	448	kPa

TYPICAL OPERATION

Operating Conditions

Heater voltage	6.0	6.0	6.0	V
Magnetic field	135	153	158	mT
Anode current (peak)	60	130	240	A
Pulse duration	5.0	4.0	2.3	μs
Duty cycle	0.003	0.0012	0.00055	
Rate of rise of voltage	125	125	125	kV/μs

Typical Performance

Anode voltage	36.5	46	51	kV
Output power (peak)	1.0	2.7	5.5	MW
Output power (mean)	3.0	3.2	3.0	kW

TEST CONDITIONS AND LIMITS

The magnetron is tested in electromagnet and launching section type MG6030 to comply with the following electrical specification at 2856, 2857.7 and 2859 MHz.

Test Conditions – Oscillation 1

Heater voltage (for test)	-	8 V
Output window cooling air flow (max)	-	0.08 m ³ /minute
Waveguide air pressure (max)	-	310 kPa abs.
Electromagnet current	-	23 A
Anode current (peak)	-	140 A
Duty cycle	-	0.0012
Pulse duration (see note 12)	-	3.0 μs
VSWR at the output coupler	-	See note 13
Rate of rise of voltage pulse (see note 11)	-	140 to 150 kV/μs

Test Limits – Oscillation 1

	Min	Max	
Anode voltage (peak)	28	32	kV
Output power (mean)	1700	-	W
Frequency (see note 14)	2856	2859	MHz
RF bandwidth at 6 dB	-	1.0	MHz
Stability (see note 15)	-	0.5	%
Frequency pulling (see note 16)	-	4.5	MHz
Heater current	-	See note 17	
Temperature coefficient of frequency	-	See note 18	

Test Conditions – Oscillation 2

Heater voltage (for test)	-	8 V
Output window cooling air flow (max)	-	0.08 m ³ /minute
Waveguide air pressure (max)	-	400 kPa abs.
Electromagnet current	-	32 A
Anode current (peak)	-	210 A
Duty cycle	-	0.0006
Pulse duration (see note 12)	-	3.0 μs
VSWR at the output coupler	-	See note 13
Rate of rise of voltage pulse (see note 11)	-	140 to 150 kV/μs

Test Limits – Oscillation 2

	Min	Max	
Anode voltage (peak)	46	50	kV
Output power (mean)	2180	-	W
Frequency (see note 14)	2856	2859	MHz
RF bandwidth at 6 dB	-	-	MHz
Stability (see note 15)	-	-	%
Frequency pulling (see note 16)	-	-	MHz
Heater current	-	See note 17	
Temperature coefficient of frequency	-	See note 18	

END OF LIFE CRITERIA

(Under Test Conditions Oscillation 2, see note 19)

Output power (mean) (see note 20)	-	2500 W min
RF bandwidth at 6dB	-	2.0 MHz max
Frequency (see note 14)	-	2856 to 2859 MHz
Stability	-	1.0 % max

NOTES

1. The ideal supply would be an amplifier that can be driven positive or negative by a DC input signal.
2. The frequency range 2856 to 2859 MHz is achieved at all conditions. The frequency at any tuner setting will increase by 630 kHz per kW reduction in mean input power. For other conditions, contact e2v technologies.
3. The magnetron must be protected from the load by an isolator or circulator. The maximum VSWR at 2856

MHz is 1.3:1 and must not exceed 2:1 over the range 2800 to 3500 MHz.

4. With no anode input power. Prior to the application of anode voltage, the cathode must be heated to the required initial temperature by the application of 13 V to the heater for at least six minutes. Within 30 seconds after the application of anode voltage the heater must be reduced as follows:

Mean input power (kW)	Heater voltage (V)
0 – 2	12.0
2 – 4	10.0
4 – 6	8.0
6 – 7	6.0

The heater voltage must be maintained within ±5% of the specified value. A rectified supply is recommended for operating the magnetron. The use of any AC supply may cause frequency modulation. e2v technologies should be consulted if the magnetron is to be operated with any supply other than DC.

A coaxial lead must be used to connect the magnetron to the filament transformer or pulse transformer, the outer being the cathode pulse connection. Capacitors must be used to prevent pulse voltages being applied to the heater, either from unbalance of a bifilar pulse transformer or by induction from the pulse current; this protection must be effective both for normal operation and in the event of the magnetron sparking. Capacitors up to 10 μF may be required, shunted by small high frequency capacitors.

5. A positive current results in a frequency increase.
6. The coil will overheat without the specified cooling through the water jacket.
7. The minimum air pressure in the output waveguide can vary with the peak power level at which the magnetron is operated. It should not be less than 172 kPa at 1 MW, 241 kPa at 3 MW and 310 kPa at 5 MW. At the maximum pressure of 448 kPa the leakage will not exceed 0.03 litre (NTP) per minute. The output waveguide may also be filled with an arc suppressant gas, such as SF₆ to a minimum static gauge pressure of 28 kPa. When using such a gas, it is mandatory that the waveguide be emptied and refilled with new arc suppressant gas at regular intervals to avoid possible dilution or contamination. The interval should not exceed 2 months or 100 hours of high voltage application, whichever is reached first. The gas should also be replaced immediately if arcing in the output waveguide is suspected, as such arcing may cause loss of stability in the magnetron.
8. Measured at the point indicated on the electromagnet outline drawing; the axial distribution must be that produced by the MG6030 electromagnet or authorised equivalent.

9. The modulator must have an efficient overswing damping system, such that the pulse energy delivered to the magnetron following an arcing pulse does not appreciably exceed the normal pulse energy. An interlock relay must be used to trip the modulator in the event of excessive magnetron arcing, preferably operated by the overswing diode current. The trip should operate if the magnetron arcs for 25 consecutive pulses. Positive overswing at the end of the voltage pulse should be less than 10% of drive voltage.

10. The various parameters are related by the formula:

$$P_i = I_{apk} \times V_{apk} \times Du$$

Where;

P_i = mean input power in w

I_{apk} = peak anode current in amperes

V_{apk} = peak anode voltage in volts

Du = duty cycle

11. The rate of rise of voltage is defined as the steepest tangent to the leading edge of the voltage pulse above 80% amplitude.

12. Tolerance $\pm 10\%$.

13. The load termination of the magnetron during this test is a waveguide with a VSWR of less than 1.1:1 at the oscillation frequency and less than 1.5:1 between 3200 and 3500 MHz.

14. The magnetron tuning range includes the two limits given.

15. Pulses are defined as missing when the RF energy level is less than 70% of the normal energy level in the frequency range 2852 to 2861 MHz. Missing pulses are expressed as a percentage of the number of input pulses applied during any 5 minute interval of a 10 minute test period.

16. Measured with a VSWR of 1.3:1 at the frequency of oscillation, varied through all phases.

17. Measured with a heater voltage of 13 V and no anode input power, the heater current limits are 13 A minimum, 15 A maximum.

18. Design test only. The maximum frequency change with anode temperature change (after warming) is -0.05 MHz/ $^{\circ}$ C.

19. The heater will be operated at 8 V for the duration of the life test and for subsequent specification tests.

20. If the mean output power falls below 2500 W, the duty cycle may be reduced to 0.0005.

HEALTH AND SAFETY HAZARDS

e2v magnetrons are safe to handle and operate provided that the relevant precautions stated herein are observed. e2v does not accept responsibility for damage or injury resulting from the use of electronic devices it produces. Equipment manufacturers and users must ensure that adequate precautions are taken. Appropriate warning labels and notices must be provided on equipment incorporating e2v devices and in operating manuals.



High Voltage

Equipment must be designed so that personnel cannot come into contact with high voltage circuits. All high voltage circuits and terminals must be enclosed and fail-safe interlock switches must be fitted to disconnect the primary power supply and discharge all high voltage capacitors and other stored charges before allowing access. Interlock switches must not be bypassed to allow operation with access door open.



RF Radiation

Personnel must not be exposed to excessive RF radiation. All RF connectors must be correctly fitted before operation so that no leakage of RF energy can occur and the RF output must be coupled efficiently to the load. It is particularly dangerous to look into open waveguide or coaxial feeders while the device is energized. Screening of the cathode sidearm of high power magnetrons may be necessary.



X-Ray Radiation

High voltage magnetrons emit a significant intensity of X-rays not only from the cathode sidearm but also from the output waveguide. These rays can constitute a health hazard unless adequate shielding of X-ray radiation is provided. This is a characteristic of all magnetrons and the X-rays emitted correspond to a voltage much higher than that of the anode.

TYPICAL PERFORMANCE CHART

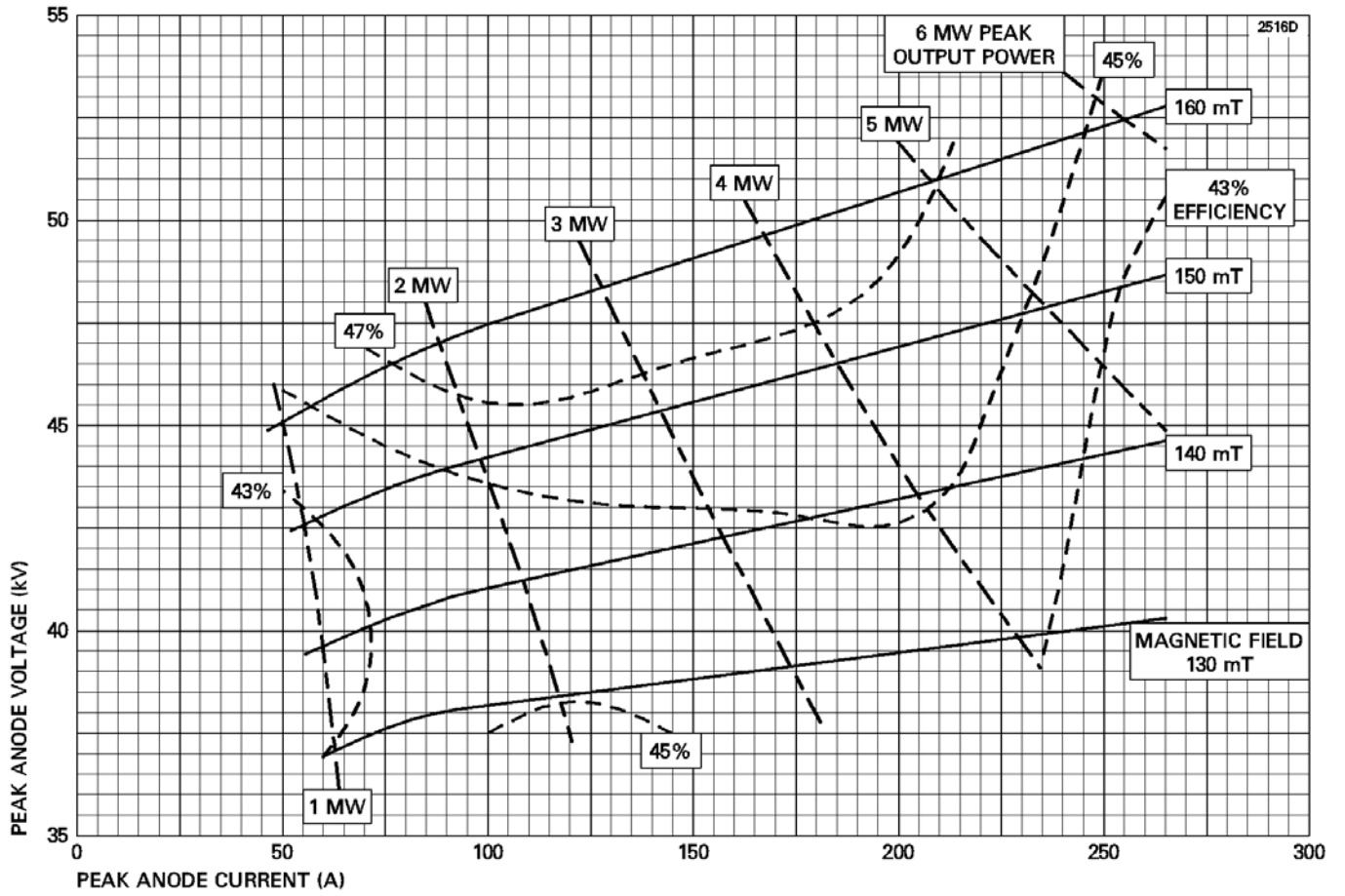

OUTLINE

(All dimensions without limits are nominal)

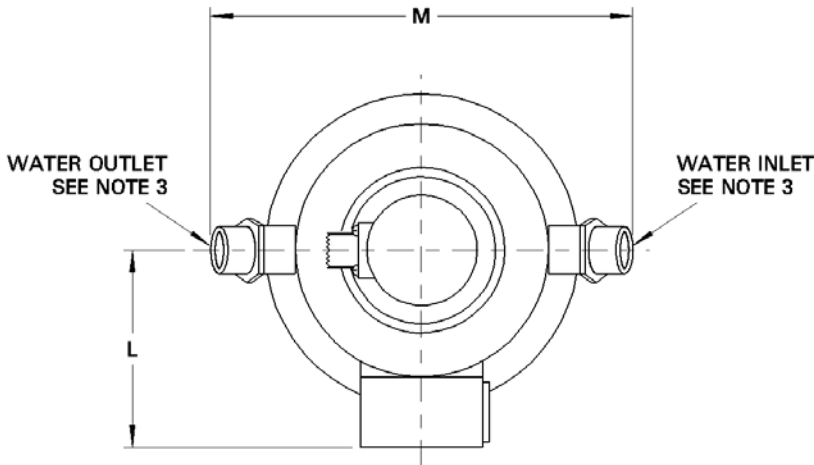

Ref	Millimetres
A	254.0 max
B	222.3 max
C	146.7 max
D	33.02 ± 3.18
E	57.15 max
F	120.7
G	76.2 max
H	116.2
J	144.5
K	101.6 max
L	94.0 max
M	190.5

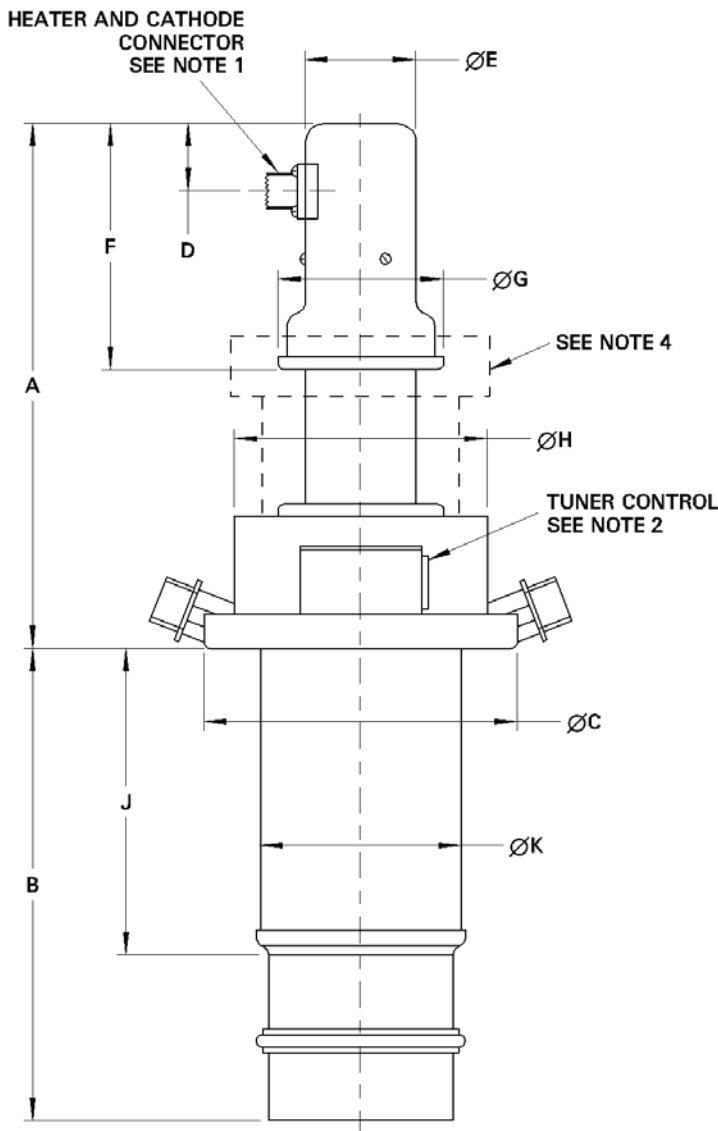

Outline Notes

1. Heater-cathode connector is a UHF 50 Ω coaxial socket; the corresponding plug is MIL STD PL259 with PTFE insulator. The cathode connection is the outer shell of the socket.
2. The tuner connector is a NEUTRIK Speakon 4-pole (NL4MP). The mating plug required is a NEUTRIK Speakon NL4FC. No connection must be made to pins +2 or -2 as these could be used internally. The coil is connected between pins -1 and +1, equivalent to negative and positive drive current. Neither side is earthed and the coil is isolated by >1 MΩ from ground.
3. Water connections 1/2-inch BS screwed pipe to BS 2051 part 2.
4. Radiation absorber MG6016 optional accessory.