

# Sona sCMOS

## The Ultimate Camera for Microscopy

### Key Specifications

- ✓ High sensitivity: up to 95% QE
- ✓ Fast speeds: up to 74 fps
- ✓ Large field of view: up to 32 mm
- ✓ Lowest thermal noise: -45°C cooling
- ✓ Protected: UltraVac™ sensor enclosure
- ✓ Longevity: 5-year vacuum warranty

### Key Applications

- ✓ Developmental biology
- ✓ Neuroimaging
- ✓ Super-resolution
- ✓ Transcriptomics
- ✓ Intracellular trafficking
- ✓ Plasma membrane studies



NOW WITH  
SRRF-STREAM™  
TECHNOLOGY



# Introducing Sona

## The most sensitive back-illuminated sCMOS Camera

Sona is Andor's high performance, vacuum-cooled sCMOS camera platform, specifically for fluorescence microscopy. It has been designed from the ground up to extract the very best performance from the latest back-illuminated sCMOS sensors with 95% Quantum efficiency.

- 1 Extended QE Response**  
Back-illuminated sCMOS for highest possible photon collection. Capture every photon!

- 2 Market Leading Quantitative Accuracy**  
Have confidence in your data with superb data fidelity:
  - >99.7% Linearity
  - <0.5% PRNU



- 7 Uncompromised High Speeds**  
Up to 74 fps in full 16-bit! No compromise on dynamic range or noise floor. Maintains stable data transfer rates.

- 3 True Imaging Flexibility**  
Select between 6.5 and 11  $\mu\text{m}$  pixel options. Capture fast or weak signals with ease. Pre-set ROIs and flexible binning options.



- 4 Large Imaging Area**  
Up to 32 mm Field of View! Unique Antiglow technology lets you harness the full field of view without restrictions!

- 5 Camera based Super-resolution Capable**  
Unlock real-time cell friendly super-resolution from your microscope with SRRF-Stream+!

- 6 Extended Dynamic Range (EDR)**  
One snap imaging captures full 16-bit image detail. Low-and high-level information in a single image!

# Sona-11: For the Widest Field of View

The Sona-11 (32 mm) is the reference in detectors when field of view and sensitivity are required. Andor's unique technology approach enables you to usefully and uniquely access the entire 2048 x 2048 pixel array offering an impressive 32 mm sensor diagonal. The Sona-11 is well matched to imaging weak signals at high magnification (e.g. x100) and large area imaging. Study structure and processes within the cell in perfect resolution using techniques such as TIRF, super-resolution localisation or confocal. The 11  $\mu\text{m}$  pixel size of the Sona-11 provides superb photon collection efficiency to make the most of every photon in such inherently weak signal conditions.

Sona-11 (22 mm) provides the same benefits but in a smaller sensor format suited to common port sizes up to 22 mm.

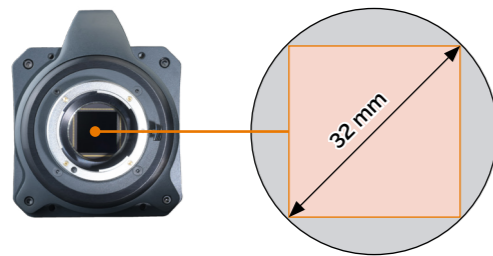

Sona-11 (32 mm)

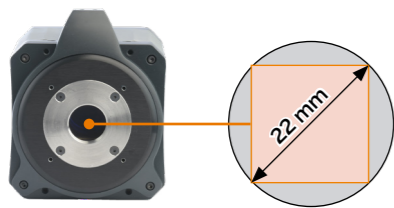

Sona-11 (22 mm)

| Summary            |                       |         |
|--------------------|-----------------------|---------|
| Model              | 4.2B-11               | 2.0B-11 |
| Sensor Size        | 32 mm                 | 22 mm   |
| Pixel Size         | 11 x 11 $\mu\text{m}$ |         |
| Quantum Efficiency | up to 95%             |         |
| Read Noise         | 1.6 e-                |         |
| Dark Current       | 0.3 e-/p/s            |         |
| Speed              | 48 fps                | 70 fps  |
| Well Depth         | 55,000 e-             |         |
| SRRF-Stream+       | Yes                   |         |
| Camera Mount       | F-mount               | C-mount |

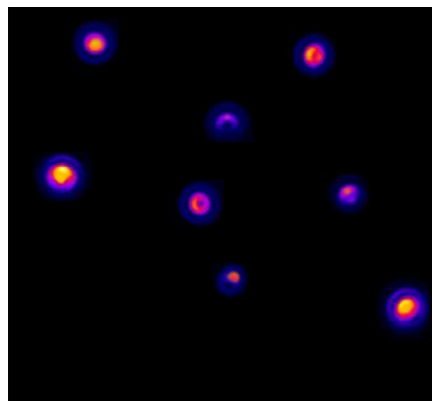

For the most demanding single molecule experiments EMCCD cameras are the most suitable. However, Sona-11 can be a viable option for stronger signals. *Image from Andor Technology.*

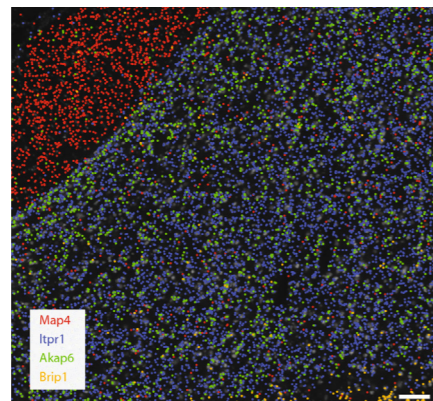

Decoded transcript locations of selected genes overlaid on stitched (n = 1 section per tissue). Scale bar, 100  $\mu\text{m}$ . Split-FISH imaging repeated on at least one additional section per tissue, with similar results. Brain tissue showing differential localisation of transcripts in regions with (Itpr1) and without (Map4) cell bodies. *(Goh et al., 2020)*

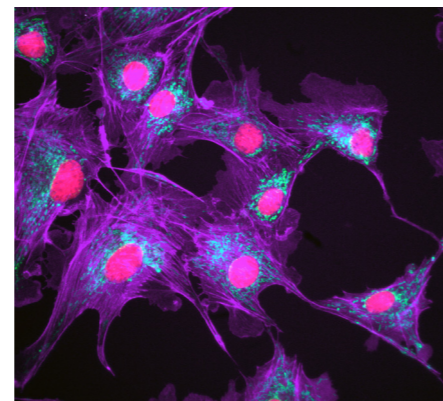

Bovine pulmonary artery endothelial cells (BPAE) imaged with Andor Sona 4.2B-11 on a Nikon Ti2 microscope at x60. Mitochondria stained with MitoTracker Red in live cells. Following fixation and permeabilization, F-actin was stained with Alexa Fluor 488 phalloidin, and nuclei with DAPI. *Dr Alan Mullan, Andor Technology.*

## Single Molecule Imaging

Single molecule imaging experiments provide insights into processes that are not possible via normal ensemble imaging. Sona-11 is an alternative to EMCCD cameras when working with brighter labels and stronger signals. In these experiments Sona-11 can provide significantly wider fields of view, higher speeds and exceptional dynamic range. Read more in our [Learning Center](#).

## Fluorescence Correlation Spectroscopy

Sona-11 (32 mm) provides the best possible solution for many FCS experiments. The largest possible sensor area, high sensitivity and high speed are complemented by class leading linearity, which allow for the most accurate and precise measurements. Read more in our [Learning Center](#).

## Transcriptomics

Detectors for such studies must have high sensitivity to help detection of the fluorescent RNA signal against the cell background. Large fields of view and high-speed are also important to maximise throughput of the image data using microarrays or tissue samples. Sona-11 (32 mm) is ideal for these studies with its combination of high sensitivity, speed and widest possible field of view. Read more in our [Learning Center](#).

## Gene Editing

The best-in-class sensitivity offered by the back-illuminated deep cooled Sona sCMOS cameras are well suited to imaging of Crispr-Cas9 constructs, ideal for fast and sensitive detection of light emitted by labelled DNA/RNA or related proteins. Read more in our [Learning Center](#).

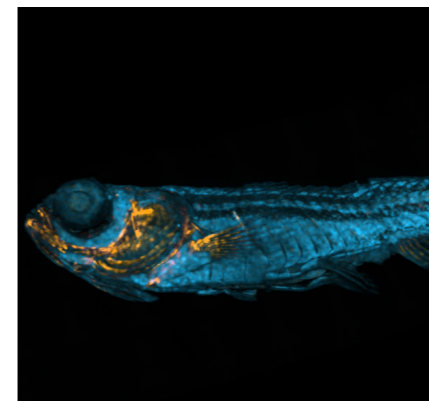

Zebrafish stitched 3D confocal image at 60x using Sona on Dragonfly and analysed using Imaris. *Sample prepared by Marco Tarasco, CCMAR (Centro de Ciências do Mar / Centre for Marine Sciences) – Universidade do Algarve. Image from Andor Technology.*

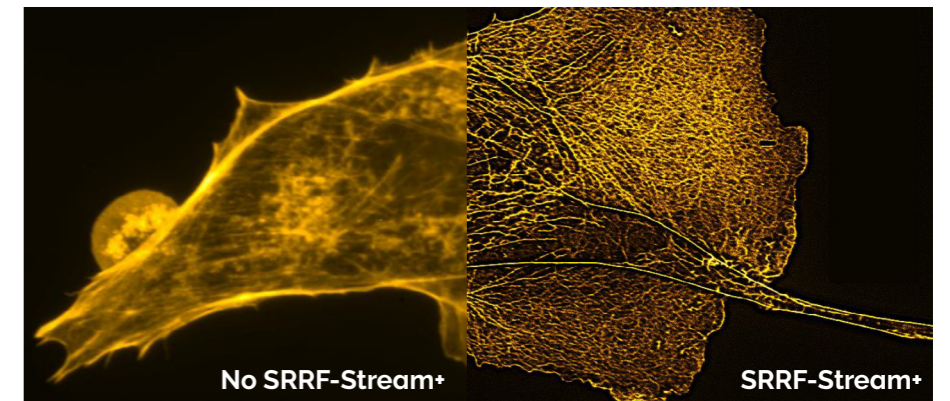

F-actin of BPAE cells labelled with Alexa Fluor 488 Phalloidin imaged on a Nikon Ti2 microscope (60x) and Sona-11. The image taken from the average of 100 frames compared against the SRRF-Stream+ image. *Images courtesy of Motosuke Tsutsumi, Research Institute for Electronic Science, Hokkaido University and National Institutes for Physiological Sciences, Aichi, Japan.*



# Sona-6: Speed & Resolution

Sona-6 features a back-illuminated sensor with 95% QE and a 6.5  $\mu\text{m}$  pixel size. This sensor format provides a perfect balance of sensitivity, speed, and resolution. Exceptionally flexible, and ideally suited to 40x and 60x magnification and today's microscope port sizes.

For low light applications, simply having a fast detector is not enough! Sona-6 provides high sensitivity and ultra-low noise floor, making it possible to image live cell applications at high frame rates with possible signal to noise. The sensitivity combines superbly with high frame rates, providing uncompromised imaging, at up to 74 fps via CoaXPress. Now available with SRRF-Stream+ super-resolution.

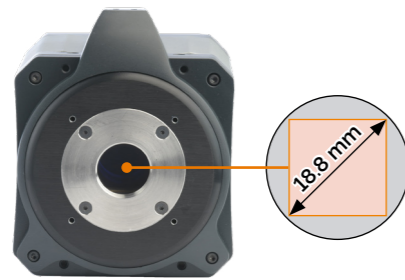

Sona-6

*"With Sona we did not have to sacrifice a large field of view to achieve high frame rate readout speeds."*

- Eric Peterson, Department of Chemistry, Utah University

| Summary            |                   |
|--------------------|-------------------|
| Model              | 4.2B-6            |
| Sensor Size        | 18.8 mm           |
| Pixel Size         | 6.5 $\mu\text{m}$ |
| Quantum Efficiency | up to 95%         |
| Read Noise         | 1.2 e-            |
| Dark Current       | 0.1 e-/p/s        |
| Speed              | 74 fps            |
| Well Depth         | 42,000 e-         |
| SRRF-Stream+       | Yes               |
| Camera Mount       | C-mount           |

## Developmental Biology

Imaging has been instrumental for following the entire lifespan of organisms to track fates of developing cells, tissues, and organs. Whole-embryo and whole-body imaging of well-established model organisms including the zebrafish and *C. elegans* can be captured in superb detail with the Sona-6 camera. Read more in our [Learning Center](#).

## Intracellular Trafficking

Fast and sensitive imaging is crucial for studies of endosome cycling, Golgi vesicles pathways, axonal transport, hormone release or synaptic vesicle pool replenishment. Sona-6 with sensitivity, resolution and speed, is ideal for tracking intricate events and dependencies occurring within the cell's vital transport and communications networks. Read more in our [Learning Center](#).

## Neuroimaging

Imaging of neurons and other specialised cells of the nervous system can be challenging for many detectors. Experiments can require high dynamic range or very sensitive detectors. Sona cameras have the required sensitivity and dynamic imaging capabilities for neuroimaging experiments. Read more in our [Learning Center](#).

## Plasma Membrane Dynamics

The plasma membrane can be imaged in many ways, which can involve direct membrane labelling with lipophilic or voltage sensitive dyes. Rapid remodelling of the plasma membrane can be imaged with the rapid frame rate, highly sensitive back-illuminated Sona cameras, perfectly suited to the low light conditions inherent to TIRF Microscopy. Read more in our [Learning Center](#).

## Organoid Studies

Organoid studies are effective in improving our understanding of diseases, in particular cancer. High sensitivity detectors are important for these studies so the subtle, yet vital cellular interactions are captured. Sona-6 is perfectly suited to such studies providing exceptional sensitivity and resolution so even the most complex image data can be accurately modelled. Read more in our [Learning Center](#).

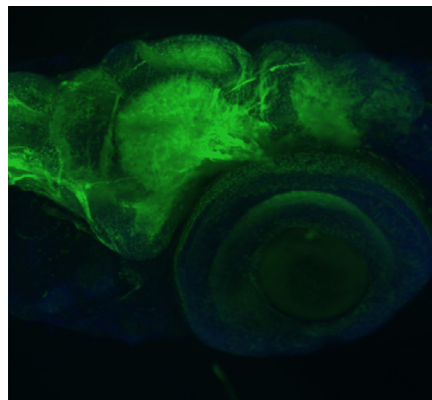

Zebrafish imaged using Sona-6, Dragonfly confocal system and Leica DMI8 (25x). Sample prepared by Marco Campinho, CCMAR (Centro de Ciências do Mar / Centre for Marine Sciences) – Universidade do Algarve. Image from Andor Technology.

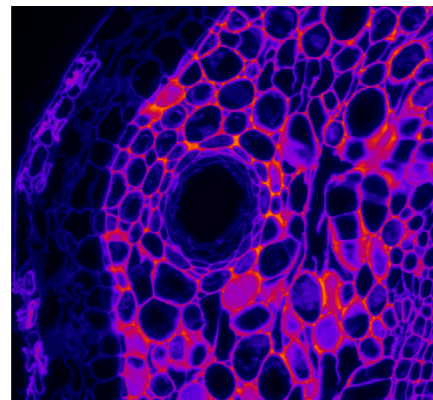

Ginkgo biloba captured using High Speed High Dynamic Range mode of Sona-6 on Nikon Ti2 Microscope. Image courtesy of Matt Renshaw, Francis Crick Institute, London.

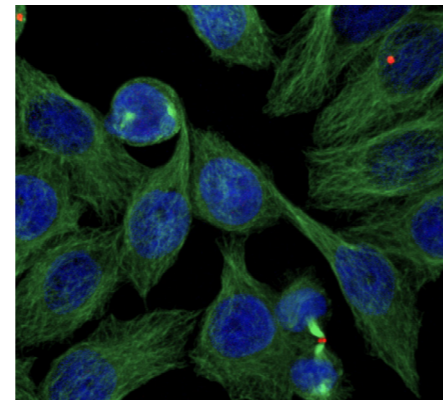

HeLa cells labelled with GFP and DAPI captured using low-noise mode of Sona-6 on Leica DMI8 microscope at 60x. Sample prepared in Álvaro Tavares Lab, (Center Biomedical Research) – Universidade do Algarve. Image from Andor Technology.

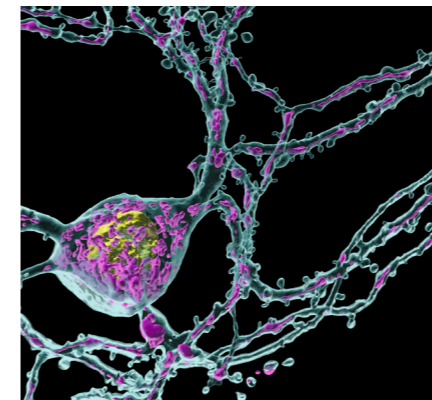

Neuron image taken using Andor sCMOS, Dragonfly, and analysed with Imaris 9.5. Image courtesy of Aubrianna Decker (Gaublomme Lab) and Daniel Virga (Polleux Lab).

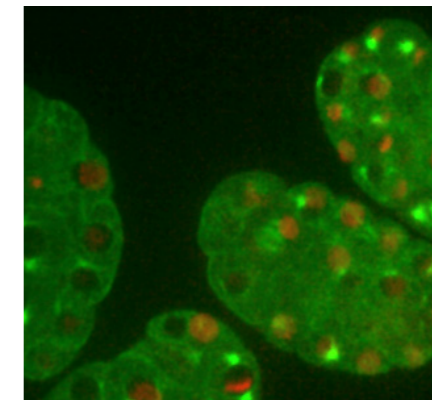

The early development of *C. elegans*, embryos labelled with GFP and mCherry, captured at 60x with Sona-6. Image Andor Technology.

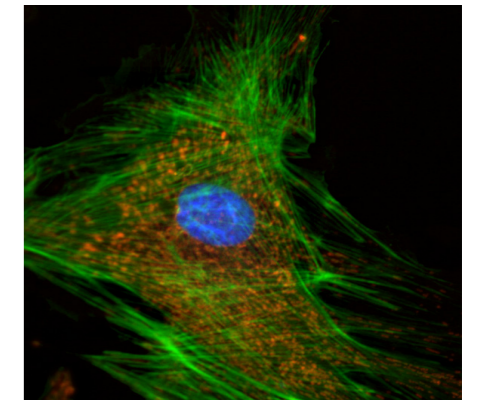

BPAE cell, MitoTracker Red™ CMXRos, Alexa Fluor™ 488 phalloidin, DAPI, from Sona-6 in low noise mode. Image Andor Technology.



# Real-Time Super-Resolution

SRRF (Super-Resolution Radial Fluctuations) offers a highly effective software-based approach to super-resolution. Working at low illumination intensities and with normal fluorescent labels makes it highly applicable to many cell biology studies (Gustafsson et al., 2016).

Andor's exclusive SRRF-Stream implementation of this technology leverages GPU optimisation to greatly increase processing speeds of the SRRF algorithm. This makes it possible to perform super-resolution microscopy on conventional modern fluorescence microscopes in real-time! Now available on Sona cameras, this fast and flexible super-resolution even more accessible to more applications!

- ✓ Real Time – enhanced workflow, avoids post-processing. View in 'Live Mode'.
- ✓ Low Excitation Intensities – prolonged live cell observations & accurate physiology.
- ✓ Conventional Fluorophores– simple labelling, no photo-switching required.
- ✓ Live Cell Dynamics – full FOV super-res images every 1-2 secs. > 10 fps using ROI.
- ✓ Cost-Effective – convert conventional fluorescence microscopes to super-resolution microscopes.

Read our [SRRF-Stream+ technical note](#) to find out more.

*"I was impressed by how easy it is to produce beautiful super-resolution images with SRRF-Stream+ and Sona."*

*Motosuke Tsutsumi*

*"SRRF" super-resolution image taken with the Sona back-illuminated sCMOS camera. Andor Insight Awards, courtesy of Motosuke Tsutsumi, Research Institute for Electronic Science, Hokkaido University and National Institutes for Physiological Sciences, Aichi, Japan.*



# Key Features

As pioneers of sCMOS technology, with the world's first sCMOS camera the Neo, we have drawn upon this vast experience to extract the best from the new generation of sCMOS sensors. Unique patented solutions, lets you get the most accurate detection possible across the widest range of imaging conditions.

## Deep & stable cooling to -45°C

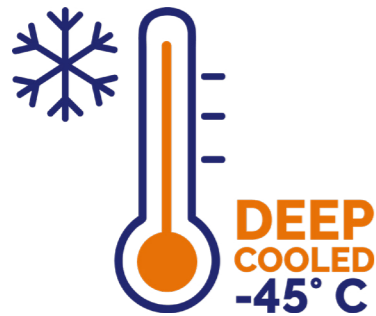

Sona extends the useable window of operation further than other back-illuminated sCMOS cameras by supressing the thermal noise with stable cooling down to -25°C (air) and -45°C (liquid). Dark current is minimised, and the impact of hot pixels reduced compared to competing cameras. Precise and stable control of temperature for the lowest possible noise floor whatever the imaging speed.

- ✓ Reduce excitation power – preserve living specimens during observation.
- ✓ Reduce fluorophore concentrations – obtain more accurate physiology.
- ✓ Imaging flexibility - study dynamic or longer duration processes alike.

Read more in our [learning center](#).

## Extended Dynamic Range

The Sona camera series offers an Extended Dynamic Range (EDR) functionality, supported by a 16-bit data range. Harnessing our innovative 'dual amplifier' sensor architecture, we can access the maximum pixel well depth AND the lowest noise simultaneously.

- ✓ Quantify extremely weak and relatively bright signal regions in one snap.
- ✓ Image and quantify challenging samples, such as neurons.

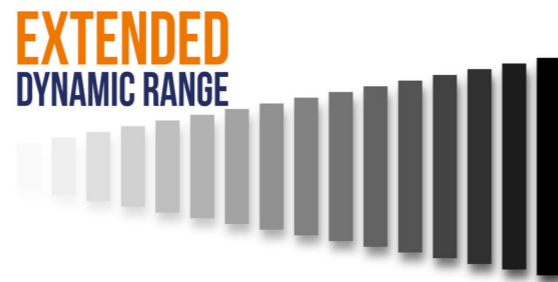

## Permanent Vacuum Technology

A permanent sealed sensor chamber provides the most reliable sensor protection and deepest cooling. Sona cameras are the only back-illuminated sCMOS cameras available that have a [permanent vacuum sealed enclosure!](#)

- ✓ Superior long-term performance.
- ✓ Best possible protection from condensation.
- ✓ 5-year warranty.

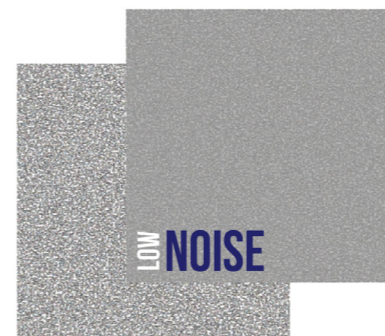
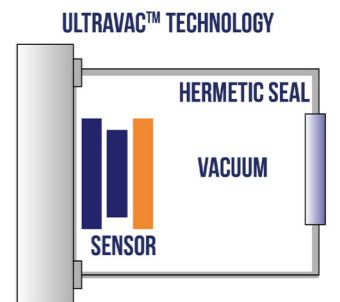

## Low Noise Technology

Sona-6 features a low noise mode optimized for the faintest and most delicate signals. [Correlated multi-sampling technology](#) reduces the noise floor, dropping read noise of the sensor, close to 1 e<sup>-</sup>.

Sona maintains high frame rates, and suitable dynamic range, unlike other cameras. This means more applications benefit from improved signal to noise performance.

- ✓ Low noise at high frame rates suits live imaging.
- ✓ High signal to noise for weak signals.
- ✓ Dynamic range for low-light confocal imaging.

## Very Large Field of View

A key feature of the GS400BSI sensor is the very large 32 mm sensor diagonal. However only Sona-11 (32 mm) allows the full sensor array to be used. Our exclusive "Antiglow" technology allows the full sensor area to be used without cropping or restriction to exposure settings.

- ✓ Use full 32 mm field of view.
- ✓ Maintains full quantitative accuracy.





# Technical Data<sup>2</sup>

| Model  | Sona-11 (32 mm)  | Sona -11 (22 mm)                        | Sona-6   |
|--|--|---|--|
| Sensor Type  | Back-Illuminated Scientific CMOS   |   |  |
| Array Size   | 2048 (W) x 2048 (H)<br>4.2 Megapixel   | 1400 (W) x 1400 (H)<br>2.0 Megapixel    | 2048 (W) x 2048 (H)<br>4.2 Megapixel   |
| Pixel Size   | 11 x 11 $\mu\text{m}$  |   | 6.5 x 6.5 $\mu\text{m}$  |
| Image Area   | 22.5 mm x 22.5 mm<br>(31.9 mm diagonal)  | 15.5 mm x 15.5 mm<br>(21.8 mm diagonal) | 13.3 mm x 13.3 mm<br>(18.8 mm diagonal)  |
| Readout Modes  | Rolling Shutter  |   |  |
| Pixel Readout Rates  | 100 MHz (High Dynamic Range mode, 16-bit)<br>200 MHz (Fast Speed mode, 12-bit)   |   | 310 MHz (Fast High Dynamic Range mode, 16-bit)<br>180 MHz (Low Noise mode, 12-bit)   |
| Quantum Efficiency <sup>3</sup>  | up to 95%  |   |  |
| Read Noise (e <sup>-</sup> ) median  | 1.6 e <sup>-</sup> (at any readout rate)   |   | 1.6 e <sup>-</sup> (Fast High Dynamic Range mode, 16-bit)<br>1.2 e <sup>-</sup> (Low Noise mode, 12-bit)                       |
| Sensor operating temperature <sup>4</sup><br>Air cooled<br>Water/liquid cooled | -25°C (up to 30°C ambient)<br>-45°C (@16°C water)  |   | -25°C (up to 30°C ambient)<br>-45°C (@16°C water)  |
| Dark Current<br>Air cooled (@-25°C)<br>Water/liquid cooled (@-45°C)            | 0.7 e <sup>-</sup> /pixel/s<br>0.3 e <sup>-</sup> /pixel/s   |   | 0.15 e <sup>-</sup> /pixel/s<br>0.10 e <sup>-</sup> /pixel/s   |
| Active area pixel well depth   | 85000 e <sup>-</sup> (High Dynamic Range mode, 16-bit)<br>2600 e <sup>-</sup> (Fast Speed mode, 12-bit, bit depth limited) |   | 42000 e <sup>-</sup> (Fast High Dynamic Range mode, 16-bit)<br>1700 e <sup>-</sup> (Low Noise mode, 12-bit, bit depth limited) |
| Dynamic Range  | 53000:1 (High Dynamic Range mode, 16-bit)  |   | 26250:1 (Fast High Dynamic Range mode, 16-bit)   |
| Data Range   | 16-bit (High Dynamic Range mode)<br>12-bit (Fast Speed mode)   |   | 16-bit (Fast High Dynamic Range mode)<br>12-bit (Low Noise mode)   |
| Linearity <sup>5</sup>   | > 99.7%  |   |  |
| PRNU   | < 0.5% (@ half-light range)  |   |  |
| Region of Interest (ROI)   | User-definable, 1 pixel granularity, min. size 25 (w) x 1 (h)  |   | User-definable, 1 pixel granularity, min. size 9 (w) x 1 (h)   |
| Pre-defined ROI  | 1608 x 1608, 1200 x 1200,<br>1024 x 1024, 512 x 512, 128 x 128   | 1024 x 1024, 512 x 512,<br>128 x 128    | 1608 x 1608, 1200 x 1200,<br>1024 x 1024, 512 x 512, 128 x 128   |
| Pixel Binning (on FPGA)  | 2 x 2, 3 x 3, 4 x 4, 8 x 8 (user-definable binning also available)   |   |  |
| I/O  | O: Fire Row 1, Fire Row n, Fire All, Fire Any, Arm, I: External  |   |  |
| Trigger Modes  | Internal, External, External Start, External Exposure, Software  |   |  |
| Software Exposure Events <sup>6</sup>  | Start exposure - End exposure (row 1), Start exposure - End exposure (row n)   |   |  |
| Image Timestamp Accuracy   | 25 ns  |   |  |
| PC Interface   | USB 3.0 <sup>7</sup>   |   | USB 3.0 <sup>7</sup> and CoaXPress   |
| Camera Window  | AR coated UV grade fused silica window   |   |  |
| Lens Mount   | F-mount  | C-mount                                 |  |

## Quantum Efficiency <sup>3</sup>

All cameras in the Sona series feature back-illuminated sensor architecture which allows optimal collection of light. Peak QE reaches 95% in the visible range with sensitivity extended across a broad wavelength range.

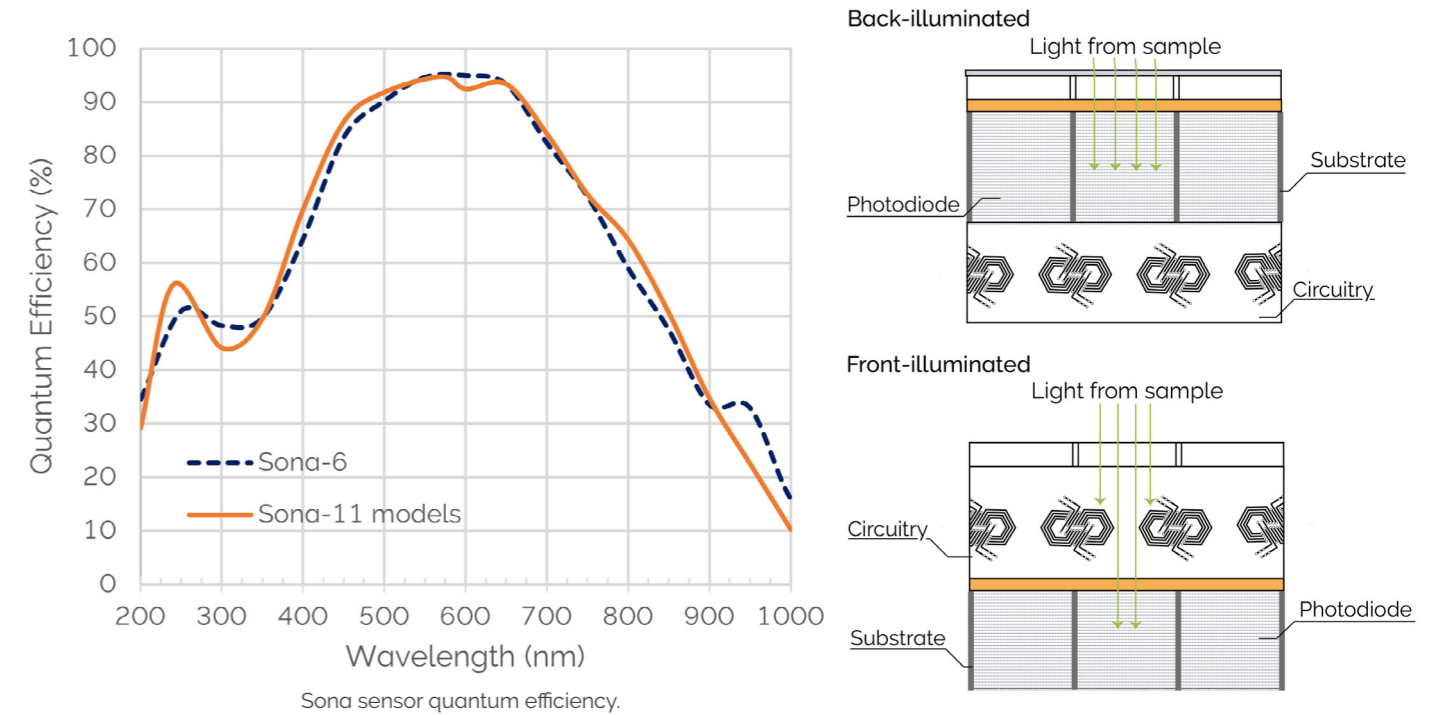

Sona sensor quantum efficiency.

Back-illuminated sensor technology maximises quantum efficiency as there is no circuitry between the signal and the photosensitive region of the sensor.

## Frame Rates

| Max Frame Rate (fps) | Sona-11 (32 mm) |                     | Sona -11 (22 mm) |                     | Sona-6 (USB3) |                    | Sona-6 (CoaXPress) |                    |
|----------------------|-----------------|---------------------|------------------|---------------------|---------------|--------------------|--------------------|--------------------|
|                      | 16-bit          | 12-bit (Fast Speed) | 16-bit           | 12-bit (Fast Speed) | 16-bit        | 12-bit (Low Noise) | 16-bit             | 12-bit (Low Noise) |
| <b>2048 x 2048</b>   | 24              | 48                  | -                | -                   | 40            | 43                 | 74                 | 43                 |
| <b>1608 x 1608</b>   | 30              | 61                  | -                | -                   | 64            | 55                 | 94                 | 55                 |
| <b>1400 x 1400</b>   | 35              | 70                  | 35               | 70                  | 85            | 63                 | 108                | 63                 |
| <b>1200 x 1200</b>   | 41              | 81                  | 41               | 81                  | 116           | 74                 | 126                | 74                 |
| <b>1024 x 1024</b>   | 48              | 95                  | 48               | 95                  | 148           | 87                 | 147                | 87                 |
| <b>512 x 512</b>     | 95              | 190                 | 95               | 190                 | 295           | 174                | 293                | 174                |
| <b>256 x 256</b>     | 190             | 378                 | 190              | 378                 | 587           | 346                | 587                | 346                |
| <b>128 x 128</b>     | 378             | 750                 | 378              | 750                 | 1165          | 686                | 1165               | 686                |
| <b>2048 x 8</b>      | 5415            | 9747                | -                | -                   | 10240         | 8928               | 15151              | 8928               |
| <b>1200 x 8</b>      | 5415            | 9747                | 5415             | 9747                | 10240         | 8928               | 15151              | 8928               |

Note: frame rates do not differ if partial or full rows are selected.



## Creating the Optimum Product for you

### Step 1. Choose the camera type

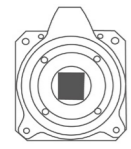

Camera Type

| Description  | Code              |
|--|-------------------|
| Sona-11 (32 mm): 4.2 Megapixel Back-illuminated sCMOS, 11 µm pixel, 95% QE, 48 fps, USB 3.0, F-mount*      | <b>SONA-4BV11</b> |
| Sona -11 (22 mm): 2.0 Megapixel Back Illuminated sCMOS, 11 µm pixel, 95% QE, 70 fps, USB 3.0, C-mount      | <b>SONA-2BV11</b> |
| Sona-6: 4.2 Megapixel Back Illuminated sCMOS, 6.5 µm pixel, 95% QE, 43 fps, USB 3.0, C-mount               | <b>SONA-4BV6U</b> |
| Sona-6: 4.2 Megapixel Back Illuminated sCMOS, 6.5 µm pixel, 95% QE, 74 fps, USB 3.0 and CoaXPress, C-mount | <b>SONA-4BV6X</b> |

\* Optional user-switchable C-Mount accessory available for use with smaller ROI sizes.

### Step 2. Select the required accessories

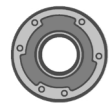

Accessories

| Description   | Order Code   |
|---|--|
| SRRF-Stream+ real time super-resolution functionality for Sona-6* <sup>a</sup>  | <b>SRRF-STREAM-SONA-6</b>  |
| SRRF-Stream+ real time super-resolution functionality for Sona-11 (32 mm) or -11 (22 mm)* <sup>a</sup>                                    | <b>SRRF-STREAM-SONA-11</b>   |
| C-mount - convert Sona-11 (32 mm) to C-mount (for use with ROIs)  | <b>ACC-MEC-11936</b>   |
| F-mount - replacement F-mount kit   | <b>F-MOUNT-ADP-KIT</b>   |
| 2x magnifying coupler unit for Sona-11 (32 mm) models for:<br>Leica microscopes<br>Nikon (TiE and Ti2) microscopes<br>Olympus microscopes | <b>MCU-SONA-LEI</b><br><b>MCU-SONA-NIK-TI</b><br><b>MCU-SONA-OLY</b> |
| Support feet recommended for side port mounting. Standard optical height 110 mm   | <b>TR-IXON-MNT-110</b>   |
| Re-circulator for enhanced cooling performance (supplied with 2x2.5 m tubing as standard)   | <b>XW-RECR</b>   |
| Oasis 160 Ultra compact chiller unit (tubing to be ordered separately)  | <b>ACC-XW-CHIL-160</b>   |
| 6 mm tubing options for Oasis 160 Ultra compact chiller (2x2.5 m or 2x5 m lengths)  | <b>ACC-6MM-TUBING-2X2.5</b><br><b>ACC-6MM-TUBING-2X5M</b>            |
| Pair of barbed hose inserts for 6 mm tubing   | <b>6MM-HOSE-BARBS</b>  |

### Step 3. Select the required software



Software

Sona requires one of the following software options:

**Solis Imaging** A 32-bit and fully 64-bit enabled application for Windows (8, 8.1 and 10) offering rich functionality for data acquisition and processing. AndorBasic provides macro language control of data acquisition, processing, display and export.

**Andor SDK3** A software development kit that allows you to control Andor sCMOS cameras from your own application. Available as a 64-bit library for Windows (8, 8.1 and 10) and Linux. Compatible with C/C++, LabView and Matlab.

Third party software compatibility Drivers are available for a variety of third party imaging packages.

[See the Andor website for detail](#)

### Upgrades

#### Order SRRF-Stream+ for Sona

Order codes for SRRF-Stream+ on your current Sona:

- **Sona-6: SRRF UPGRADE SONA-6**
- **Sona-11 or -11 (22 mm): SRRF UPGRADE SONA-11**

#### CoaXPress Upgrade

To upgrade USB 3.0 model to higher speed CoaXPress order **CHAM-UPG-CXP** code. Upgrade includes CoaXPress card, cables and remote session to upgrade camera firmware to unlock CoaXPress. Please contact your sales representative for more information.

## Mechanical Drawings

Dimensions in mm [inches]  
(shown for C-mount)

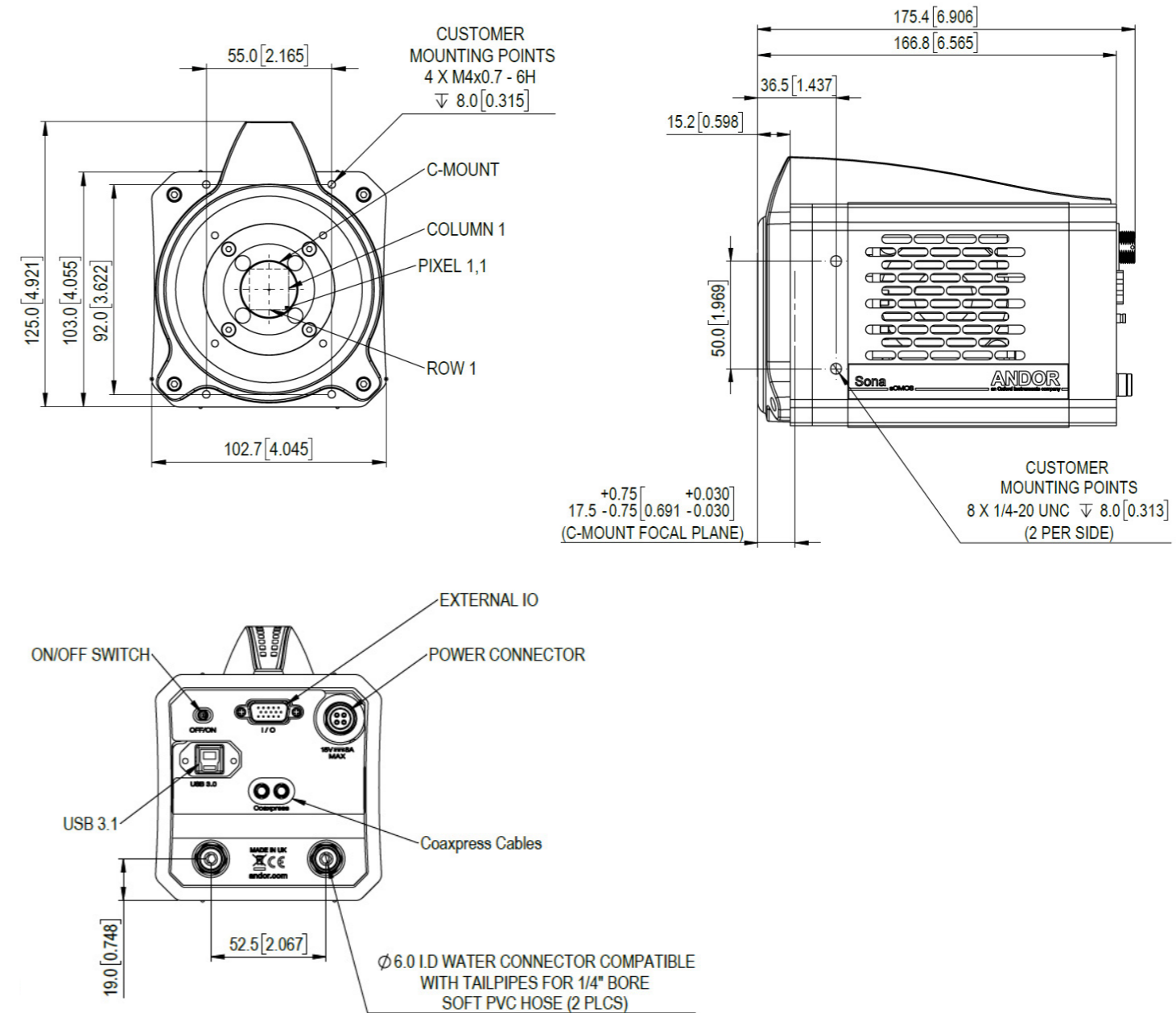

Note: Support feet are recommended for mounting on microscope side ports. Adjustable support feet. Standard optical height 110 mm. TR-IXON-MNT-110.

Note: CoaXPress connection only available with SONA-4BV6X model or via CoaXPress upgrade.

Weight: ~3 kg [6.61 lbs] approx.



# Order Today

At Andor we are committed to finding the correct solution for you. With a dedicated team of technical advisors, we are able to offer you one-to-one guidance and technical support on all Andor products.

For a full listing of our local sales offices, please see: [andor.com/contact](http://andor.com/contact)

Our regional headquarters are:

## Europe

Belfast, Northern Ireland  
Phone +44 (28) 9023 7126  
Fax +44 (28) 9031 0792

## North America

Concord, MA, USA  
Phone +1 (860) 290 9211  
Fax +1 (860) 290 9566

## Japan

Tokyo  
Phone +81 (3) 6732 8968  
Fax +81 (3) 6732 8939

## China

Beijing  
Phone +86 (10) 5884 7900  
Fax +86 (10) 5884 7901



## Items shipped with your camera

- 1x USB 3.0 PCIe card\*7
- 1x USB 3.0 Cable (3 m)\*7
- 1x Multi I/O Timing Cable (BNC to D-type: 1.5 m)
- 1x 15 V PSU
- 1x Country specific power cord
- 1x User manuals in electronic format
- 1x Quickstart Guide
- 1x Individual system performance booklet
- Sona-6 with CoaXPress also includes:
- 1x CoaXPress 3.0 PCIe card with external trigger
- 1x CoaXPress Cable (3 m)
- 1x Multi I/O Timing Cable (BNC to SMB: 1.5 m)

## Minimum Computer Requirements:

- 3.0 GHz single core or 2.4 GHz dual or quad core processor
- 8 GB RAM
- Hard drive: 850 MB/sec write speed recommended for the data rate associated with the max. frame rates. 250 MB free hard disc to install software
- USB 3.0 slot (or x4 PCIe slot for USB 3.0 card)
- x8 PCIe slot for CXP PCIe card
- Windows (8, 8.1 and 10) or Linux

## Footnotes

1. Assembled in a state-of-the-art facility, Andor's UltraVac™ vacuum process combines a permanent hermetic vacuum seal (no o-rings), with a stringent protocol and proprietary materials to minimise outgassing. Outgassing is the release of trapped gases that would otherwise degrade cooling performance and potentially cause sensor failure.
2. Figures are typical unless otherwise stated.
3. Quantum efficiency as supplied by the sensor manufacturer.
4. Coolant temperature must be above dew point.
5. Linearity is measured from a plot of Signal vs. Exposure Time over the full dynamic range.
6. Software Exposure Events provide rapid software notification (SDK only) of the start and end of acquisition.
7. The Sona connects to your control PC using a USB 3.0 connection. This may also be referred to as USB 3.1 (Gen 1). Andor provide a USB 3.0 card and cable, and recommend that these are used to ensure optimum performance.
8. Camera must be connected to suitable acquisition workstation with compatible Nvidia GPU card and supported software.

## Operating & Storage Conditions:

- Operating Temperature: 0°C to +30°C ambient
- Operating Altitude: up to 6000 m
- Relative Humidity: <70% (non-condensing)
- Storage Temperature: -10°C to 50°C

## Power Requirements:

- 100 - 240 VAC, 50 - 60 Hz
- Power consumption: 40 - 46 W typical / 114 W max (model dependent)



Windows is a registered trademark of Microsoft Corporation.  
Labview is a registered trademark of National Instruments.  
Matlab is a registered trademark of The MathWorks Inc.