

litilit

INDYLIT 10

Industrial Femtosecond Laser for material processing
1030 nm, 390 fs – 4 ps, > 10 W, 100 kHz – 2 MHz



WWW.LITILIT.COM

ROBUST DESIGN FOR FLEXIBLE APPLICATIONS

FEATURES

- Extremely robust and stable
- Adjustable repetition rate, pulse duration, power
- High pulse energy and clean pulse shape
- Passively air cooled
- Maintenance-free & turn-key

APPLICATIONS

- Material microprocessing
- Ophthalmology
- Semiconductor and electronics
- Display manufacturing
- Battery manufacturing
- Stainless steel black and color marking

INDYLIT 10

The **Indylit 10** is a high energy air-cooled femtosecond laser designed for a variety of ultrafast applications.

The laser head features innovative passively-cooled design, ensuring high stability of the optical parameters such as pulse duration, beam pointing and power. Its mechanical construction can withstand almost everything you can throw at it, making the Indylit a new industrial femtosecond technology.

Built-in second harmonics (SH) module provides wavelength extension enabling even wider range material processing applications.

SPECIFICATIONS

Model	Indylit 10	Indylit 10 SH ¹⁾
Central wavelength	1030 ± 2 nm	515 ± 1 nm
Spectral bandwidth (FWHM)	< 4 nm	< 3 nm
Average power ²⁾	> 10 W @ 100 kHz > 12 W @ 1000 kHz	> 6 W @ 150 kHz
Max. pulse energy ²⁾	> 100 µJ	> 50 µJ
Pulse duration	< 390 fs ³⁾	
Pulse duration tunability	390 fs – 4 ps	N/A
Internal pulse repetition rate	100 kHz – 2 MHz down to 30 kHz in burst mode	
Pulse picker	integrated	
Triggering mode	pulse picker control via TTL gate	
Burst length	1 ... 13 pulses	
Max. energy in burst	> 300 µJ	> 150 µJ
Power attenuation ⁴⁾	100 – 0.1%	
Beam quality	M ² < 1.2	
Beam circularity ⁵⁾	> 0.90	> 0.88
Beam diameter (at 1/e ² level)	2.4 ± 0.3 mm	2 ± 0.3 mm



Model	Indylit 10	Indylit 10 SH ¹⁾
Polarization	Linear horizontal, > 200 : 1 extinction	
Beam divergence (full angle)	< 1 mrad	
Beam pointing (RMS) ⁶⁾	< 20 μ rad	
Beam pointing vs temp.	< 20 μ rad/ $^{\circ}$ C	
Power stability (RMS) ⁷⁾	< 1.0%	< 2.0%
Pulse energy stability (RMS) ⁸⁾	< 1.0%	< 2.0%
Warm-up time (cold start)	< 30 min	
Warm-up time (warm start)	< 2 min	
Laser control interface	CAN, USB	
Operating voltage	100 ... 240 V AC, 47 ... 63 Hz	
Average power consumption (after warm-up)	< 250 W	
Operating temperature	15 – 35 $^{\circ}$ C	
Maximal power rating	600 W	
Humidity	non condensing	
Transportation/storage temperature	-20 – +70 $^{\circ}$ C	
Dimensions:		
Laser head (L x W x H)	483 x 235 x 186 mm	
Control unit (L x W x H)	449 x 370 x 140 mm	
Umbilical length	3 \pm 0.1 m	
Colling:		
Laser head	air (passive) ⁹⁾	
Control unit	forced air (fans)	

¹⁾ Indylit 10 SH model has also 1030 nm output with the same specifications as Indylit 10 model. The outputs can be switched in < 0.5 s by user.

²⁾ Please refer to the power and energy vs. pulse repetition rate curves for typical values.

³⁾ Pulse duration with external compression module down to 50 fs. For more information about pulse compression module please contact LITILIT directly.

⁴⁾ Attenuation can be controlled by a few different methods: a) via PC user interface, b) by CAN register, c) by analog input (0 - 1 V, rise time < 1 μ s). Beam quality specifications are maintained down to 10% power level.

⁵⁾ Defined as the worst case ellipticity along the z-scan ($\pm 5 \times L_{\text{Rayleigh}}$) of the beam.

⁶⁾ Measured during 8 h operation starting 30 minutes after warm-up. Environmental temperature stability within $\pm 1^{\circ}$ C.

⁷⁾ Measured with integration time of 1s at the same conditions as (6).

⁸⁾ Measured within 10 s time interval for at least 1000 pulses.

⁹⁾ Water cooling is optional. For more details please contact LITILIT.

¹⁰⁾ Technology is protected by international patents: LT6261 (B); JP6276471 (B2); US10038297 (B2); EP3178137; DK3178137 (T3); CN106575849 (B); PL3178137 (T3); LT6639 (B); LT2020 563.

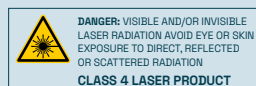

INDYLIT 10

PERFORMANCE

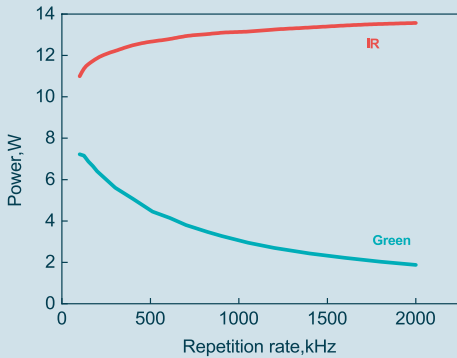

Average power dependence on the pulse repetition rate for infrared and green (SH) output

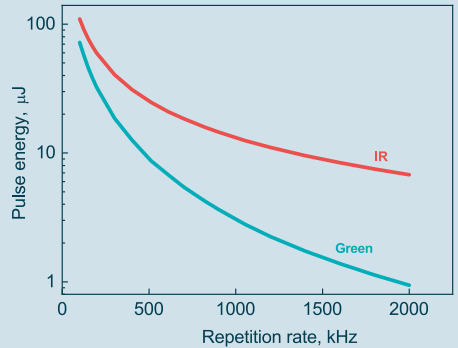

Pulse energy dependence on the pulse repetition rate for infrared and green (SH) output

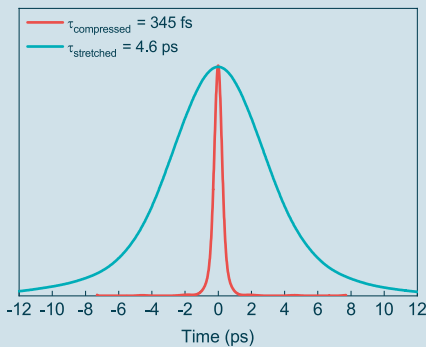

Pulse autocorrelation traces of compressed and maximally stretched 100 µJ pulses

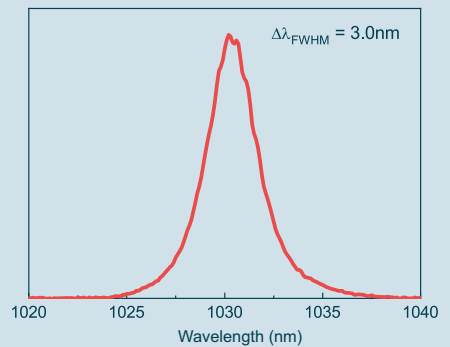

Optical spectrum

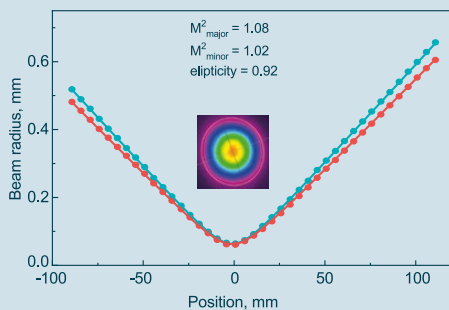

Beam quality measurement and beam profile in far field

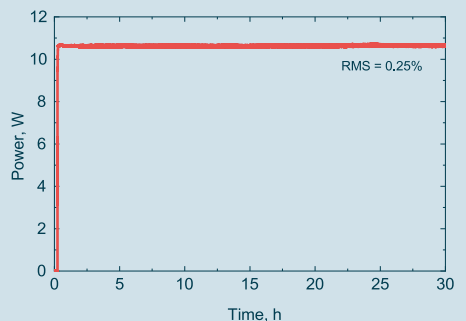

Power stability measurement after cold start

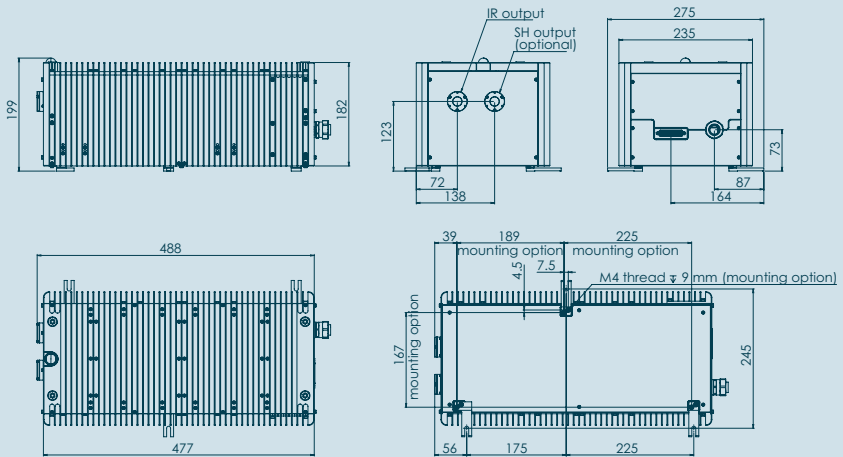

Drawing of Indylit 10 laser head (in mm)

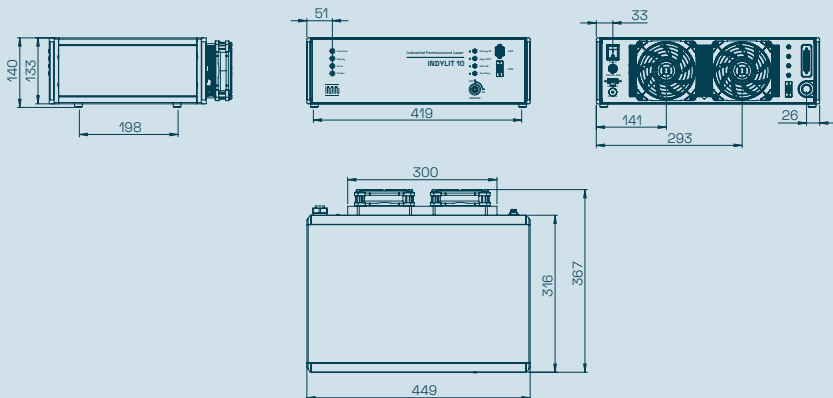

Drawing of Indylit 10 laser power supply (in mm)

