

- MHM10-PROF, standard encoder Ø58mm with Profibus interface:
- Robust and compact conception
- Solid shaft version Ø 10 mm (Ø6 mm available upon request)
- Precision ball bearings with sealing flange
- High temperatures performances -40°C ... +85°C
- Code disc made of unbreakable and durable plastic
- Mechanical memorisation of the number of turns by gears
- Resolution : 13 bits = 8192 steps/turn (max 16 bits)
- Number of turns : 12 bits = 4096 turns (max 14 bits)
- Polarity inversion and short circuit protection
- Highly integrated circuit in SMD-technology

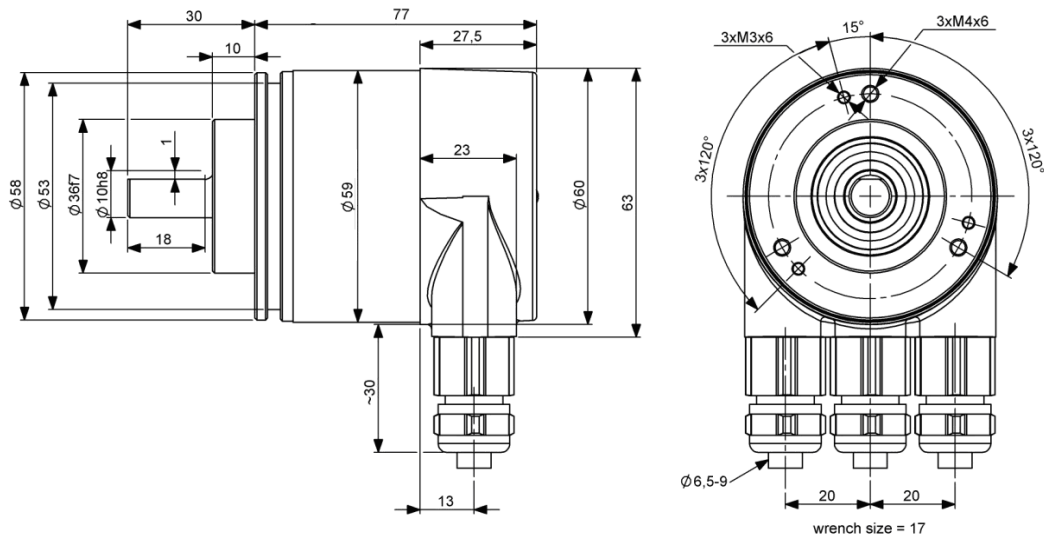

MHM510-PROF (connection cap included)



| Red LED  | Green LED | Status / possible cause   |
|----------|-----------|---|
| Dark     | Dark      | No power supply   |
| Bright   | Bright    | Encoder is ready for operation but it has not received any configuration data after power on.<br>Possible causes: address setting incorrect, Bus lines not connected correctly                      |
| Bright   | Flashing  | Parameter or configuration error. The encoder receives configuration or parameter data of incorrect length or inconsistent data<br>Possible cause: parameter value "total measuring range" too high |
| Flashing | Bright    | The encoder is ready for operation but not addressed by the master (e.g. incorrect address in configuration).   |
| Bright   | Dark      | Encoder has not received any data for a longer period (about 40 sec.)<br>Possible cause: bus line has been interrupted  |
| Dark     | Bright    | Normal operation in data exchange mode  |
| Dark     | Flashing  | Commissioning mode  |

Led status at the front of the connection cap

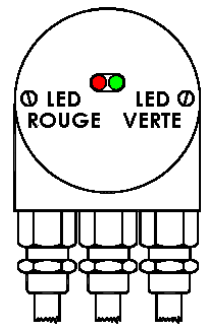

### MECHANICAL DATA

|                             |                           |   |                          |                        |                 |  |
|-----------------------------|---------------------------|---|--------------------------|------------------------|-----------------|--|
| Material                    | Cover : aluminum          | Vibrations (EN 60068-2-6)   | ≤ 10 g (10Hz... 1 000Hz) |                        |                 |  |
|                             | Body : aluminum           |   | Weight                   | 600 g                  |                 |  |
|                             | Shaft: stainless steel    |   |                          | Operating temperature  | - 40 ... + 85°C |  |
| Max. shaft loading          | Axial : 40 N              | Storage temperature   | - 40 ... + 85°C          |                        |                 |  |
|                             | Radial : 110 N            |   | Humidity                 | 98 % sans condensation |                 |  |
| Shaft Inertia               | ≤ 30 g.cm <sup>2</sup>    | Protection class (EN 60529)   |                          | IP65: cover            |                 |  |
| Torque                      | ≤ 3 N.cm                  |   | IP64: shaft              |                        |                 |  |
| RPM (continuous operation)) | 6 000 rpm                 | Lifetime in 10 <sup>8</sup> revolutions with F <sub>a</sub> / F <sub>r</sub> (axial/radial) |                          |                        |                 |  |
| Shock (EN 60068-2-27))      | ≤ 100 g (halfsinus, 6 ms) | 40 N / 60 N   | 40 N / 80 N              | 40 N / 110 N           |                 |  |
| Shock (EN 60028-2-29)       | ≤ 10 g (half-sinus, 16ms) | 25  | 10                       | 4                      |                 |  |

### ELECTRICAL DATA

|                     |                    |                     |                           |
|---------------------|--------------------|---------------------|---------------------------|
| Interface           | ISO 11898          | Power consumption   | max 2,5W                  |
| Transmission rate   | Max 12 MBauds      | Step Frequency LSB  | 800 kHz                   |
| Device addressing   | by rotary switches | Accuracy            | + 1/2 LSB                 |
| Power supply        | 10 – 30Vdc         | EMC                 | EN 61000-6-4 EN 61000-6-2 |
| Current consumption | max 100mA (24Vdc)  | Electrical lifetime | > 10 <sup>5</sup> h       |

### PROGRAMMABLE PARAMETERS

The Profibus-DP interface supports CLASS 1 and CLASS 2 functionality according to the encoder profile . In addition to these functions the GSD-file supports further features, for example software limit switches. Further more, the following encoder parameters can be programmed directly via the Profibus-DP network without any extra device

|                                    |  |
|------------------------------------|--|
| Counting Direction                 | This parameter counting direction defines whether the output code increases or decreases when the shaft rotates clockwise.   |
| Resolution (positions per turns)   | The parameter 'resolution per revolution' is used to program the desired number of steps per revolution. Each value between 1 and the physical resolution per revolution can be programmed   |
| Total Resolution "Max-RANGE"       | This parameter is used to program the desired number of measuring units over the total measuring range. This value may not exceed the total physical resolution of the absolute rotary encoder   |
| Reset (RAX)                        | The preset value is the desired position value, which should be reached at a certain physical position of the axis. The position value is set to the desired process value by the parameter preset   |
| Velocity                           | The implemented software can additionally deliver the current velocity. This value is transmitted in binary code, 16 Bit, in addition to the process value<br>It is possible to choose between four different units: steps per 10 ms, per 100 ms, per 1000 ms and revolutions per minute |
| Software limit switches function   | Two software limit switches can be set. If the position value falls below the lower or exceeds the higher limit switch, a status bit in the process value is set   |
| Teach-in (Online parameterization) | A special mode is available for commissioning phase of the device. This makes it possible to change parameters while the encoder is in data exchange mode  |

### INTERFACE

The rotary encoder is connected by two or three cables, depending on whether the power supply is integrated into the bus cable or connected separately. If the power supply is integrated into the bus cable one of the cable glands can be fitted with a plug. The cable glands are suitable for cable diameters from 6.5 up to 9 mm

The Profibus-DP device address is set by user-friendly rotary switches in the connection cap. Allowed addresses are between 1 and 99, each can only be used once. The connection cap can easily be opened for installation by removing the two cap screws

Termination resistors are integrated in the connection cap. These must be switched on if the encoder is connected at the end or the beginning of the bus

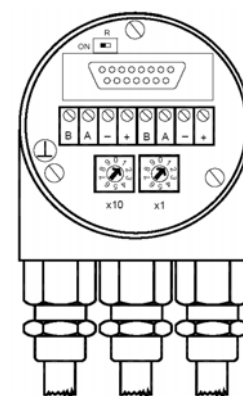

### ORDERING REFERENCE Contact the factory for special versions, ex: electronics, special flanges, connections...)

| MHM5                        | DP       | C1      | B             | 12   | 13  | C            | 10                      | 0                         | H3P            |
|-----------------------------|----------|---------|---------------|--|---|--------------|-------------------------|---------------------------|----------------|
| Absolute multi turn encoder | Profibus | Version | Code : Binary | Number of turns<br>2 <sup>12</sup> (4 096) | Resolution (pos./turn)<br>2 <sup>13</sup> (8 192) | Clamp Flange | Shat diameter :<br>10mm | Without mechanical option | Connection Cap |

**Note:** The "H3P" terminal box version is shorter than the "0CC" one.