

## 3025 MICROSCOPE SERIES INSTRUCTIONS

### **Polysciences, Inc.**

400 Valley Road  
Warrington, PA 18976

(800) 523-2575 / (215) 343-6484  
(800) 343-3291 / (215) 343-0214 fax  
info@polysciences.com  
www.polysciences.com

### **Polysciences Europe GmbH**

Handelsstrasse 3  
D-69214 Eppelheim  
Germany

(49) 6221-765767  
(49) 6221-764620 fax  
info@polysciences.de

### **Asia-Pacific Headquarters**

Polysciences Asia Pacific, Inc.  
2F-1, 207 DunHua N. Rd.  
Taipei, Taiwan 10595

(886) 2 8712 0600  
(886) 2 8712 2677 fax  
info@polysciences.tw

Our catalog lists over 3,000 unique and specialty products that are used by histology professionals, lab technicians, pathologists, chemists and scientists worldwide. Visit [www.polysciences.com](http://www.polysciences.com) to learn more about our product lines.

## TABLE OF CONTENTS

Safety notes.....	<i>i</i>
Care and Maintenance.....	<i>ii</i>
<b>1. Components Illustration.....</b>	<b>1</b>
<b>2. Installation of Components.....</b>	<b>4</b>
2.1 Installation Diagram.....	4
2.2 Installation Procedures.....	5
<b>3. Operation.....</b>	<b>11</b>
<b>4. Technical Specifications.....</b>	<b>15</b>
<b>5. Trouble Shooting Guide.....</b>	<b>16</b>

## **SAFETY NOTES**

1. Open the shipping carton carefully to prevent any accessory, i.e. objectives or eyepieces, from dropping and being damaged.
2. Do not discard the molded Styrofoam container; the container should be retained should the microscope ever require reshipment.
3. Keep the instrument out of direct sunlight, high temperature or humidity, and dusty environments. Ensure the microscope is located on a smooth, level and firm surface.
4. If any specimen solutions or other liquids splash onto the stage, objective or any other component, disconnect the power cord immediately and wipe up the spillage. Otherwise, the instrument may be damaged.
5. **CAUTION:** the lamp, lamp housing and adjacent parts will become very hot. Do not touch these parts until they have completely cooled. Never attempt to handle a hot halogen bulb.
6. All electrical connectors (power cord) should be inserted into an electrical surge suppressor to prevent damage due to voltage fluctuations.
7. For safety when replacing the halogen lamp or fuse, be sure the main switch is off ("O"), remove the power cord, and replace the halogen bulb after the bulb and the lamp house has completely cooled.
8. Confirm that the input voltage indicated on your microscope corresponds to your line voltage. The use of a different input voltage than indicated will cause severe damage to the microscope.

## **CARE AND MAINTENANCE**

1. Do not attempt to disassemble any component including eyepieces, objectives or focusing assembly.
2. Keep the instrument clean; remove dirt and debris regularly. Accumulated dirt on metal surfaces should be cleaned with a damp cloth. More persistent dirt should be removed using a mild soap solution. Do not use organic solvents for cleansing.
3. The outer surface of the optics should be inspected and cleaned periodically using an air stream from an air bulb. If dirt remains on the optical surface, use a soft cloth or cotton swab dampened with a lens cleaning solution (available at camera stores). All optical lenses should be swabbed using a circular motion. A small amount of absorbent cotton wound on the end of a tapered stick makes a useful tool for cleaning recessed optical surfaces. Avoid using an excessive amount of solvents as this may cause problems with optical coatings or cemented optics or the flowing solvent may pick up grease making cleaning more difficult. Oil immersion objectives should be cleaned immediately after use by removing the oil with lens tissue or a clean, soft cloth.
4. Store the instrument in a cool, dry environment. Cover the microscope with the dust cover when not in use.

## COMPONENTS ILLUSTRATION

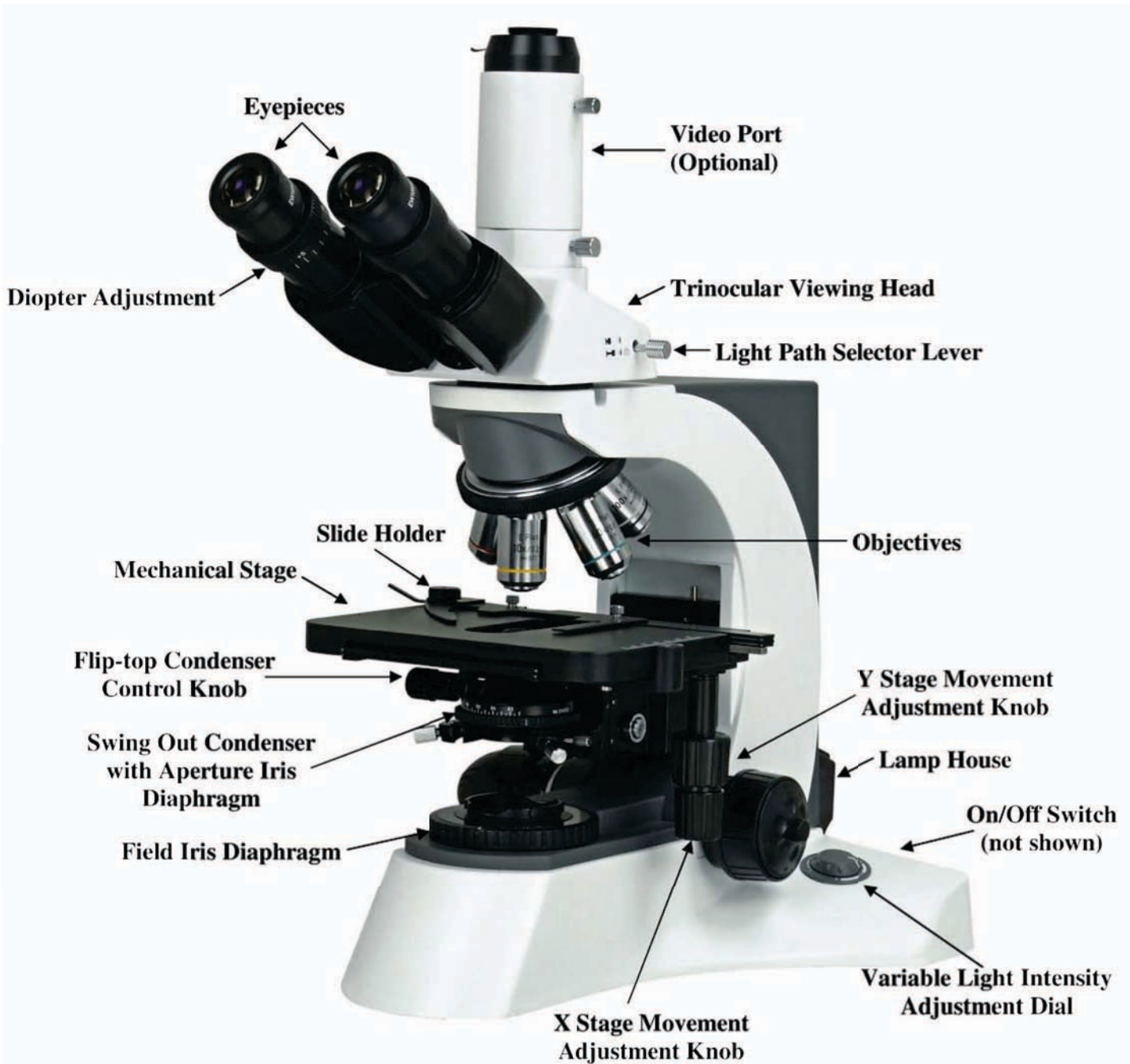

## **3025 MICROSCOPE SERIES**

**2-1 Installation Diagram**

The figure on the following page shows the correct installation sequence of the components. Follow the numerical sequence of each numbered component in the figure.

**DO NOT ATTEMPT TO ASSEMBLE THE MICROSCOPE IN A DIFFERENT SEQUENCE THAN INDICATED.**

**Before assembly, be sure every component is clean.**

**Do not discard the two hexagonal Allen wrenches. They will be required when changing components or disassembly.**

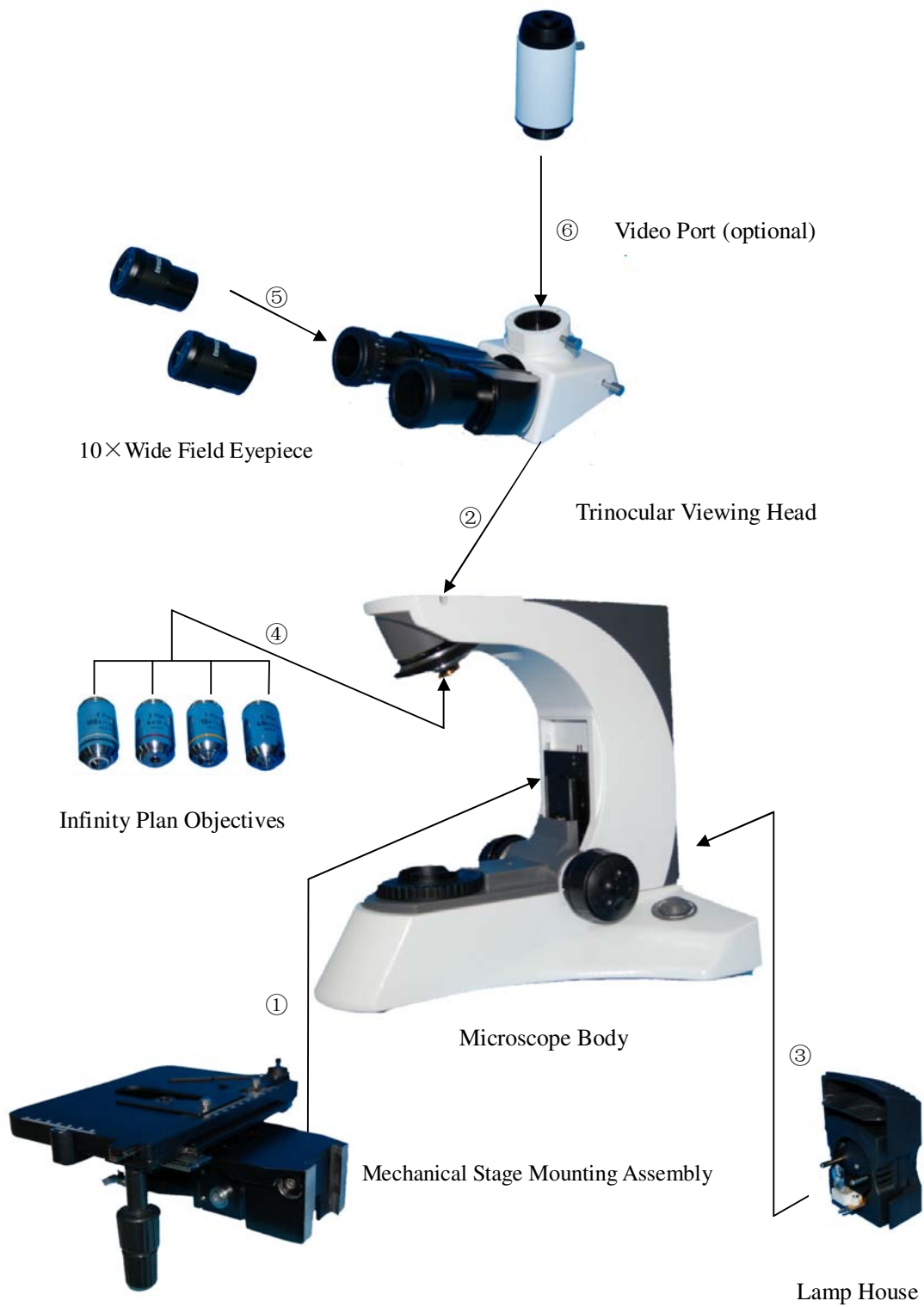

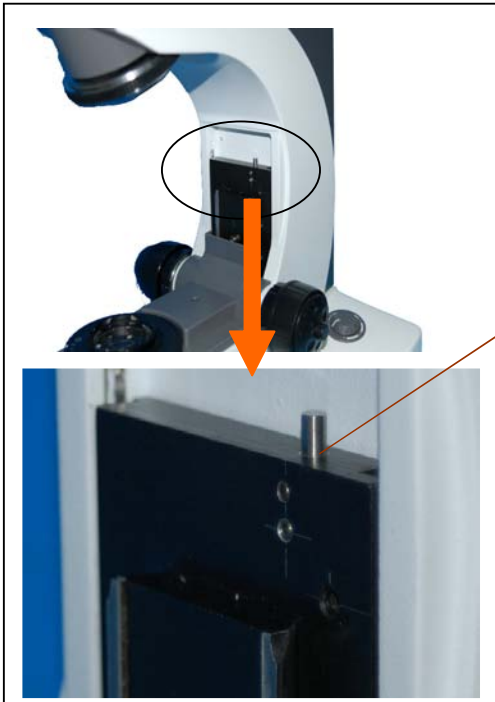

Guide Board

Figure 1

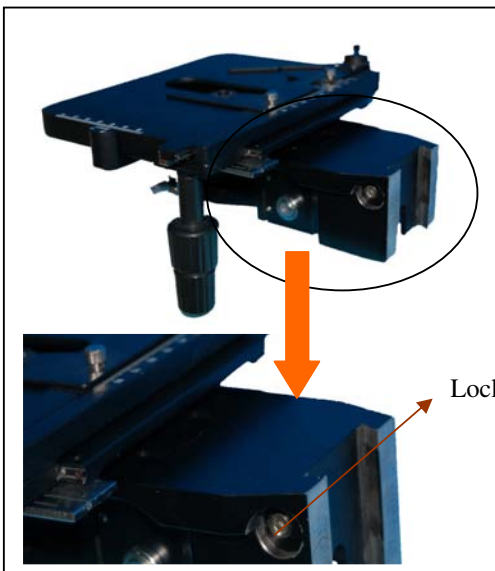

Locking Block and Bolt

Figure 2



Figure 3



### **2-2-1 Installing the Mechanical Stage Mounting Assembly**

1. Before installing the mechanical stage mounting device, be sure to adjust the coarse focus knob until the guide board (Figure 1) is at its lowest position. This allows you to install the mechanical stage easily. Use the 3.0mm hexagonal Allen wrench to connect the mechanical stage mounting support assembly and the guide board. Ensure the connection is tight and secure.
2. Place the mechanical stage mechanical assembly (Figure 2) onto the top of the guide board (Figure 1). Ensure the assembly (Figure 2) is completely attached to the guide board before tightening the allen screw.

**The mechanical stage has been factory assembled and adjusted. Disassembly of the mechanical stage should be attempted only by a trained microscope service technician.**

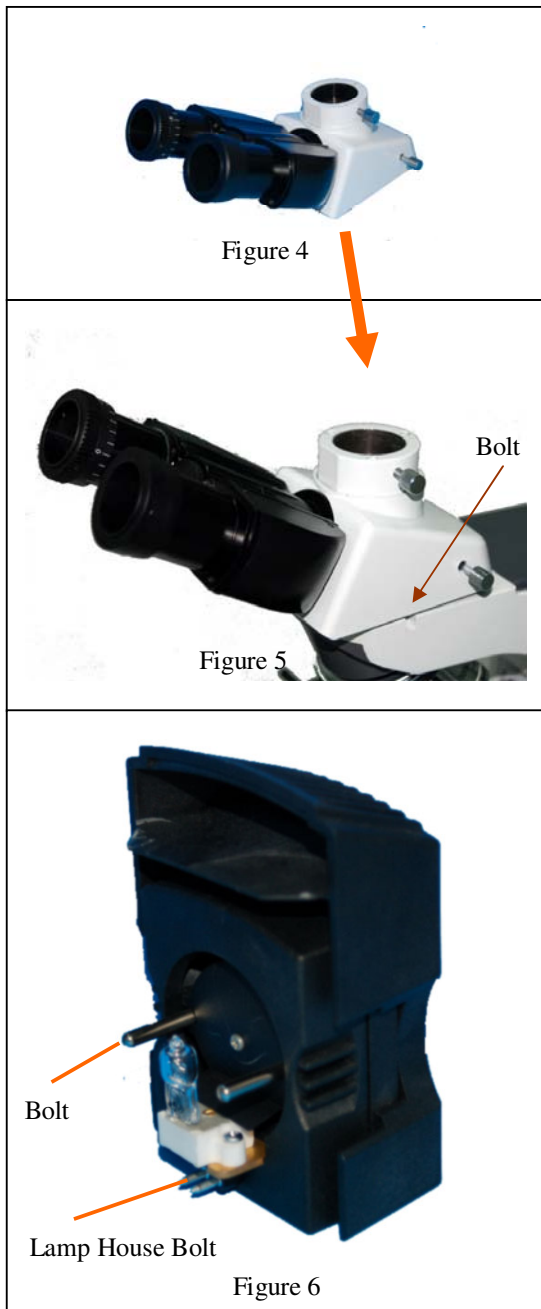

### 2-2-2 Installing the Trinocular Viewing Head

Insert the trinocular viewing head (Fig.4) into the microscope body (Fig. 5); then rotate the head into its proper viewing position. Use the 2.5mm hexagonal wrench to attach the viewing head to the body by tightening the allen screw. Ensure the head is securely attached.

### 2-2-3 Installing and Replacing the Lamp (Figure 6)

❖ **Halogen Lamp: 6 Volt 30 Watt: Do not use a lamp of a different voltage or wattage.**

1. Turn the power switch to the off position and remove the power cord.
2. Allow the lamp house and bulb to completely cool. Remove the lamp housing by pulling gently. Remove the old lamp from the socket and replace with a 6V30W halogen lamp.

**Do not touch the halogen lamp with your bare fingers. Doing so will shorten the service life of the lamp. Use a soft, clean cloth or lint free paper tissue.**

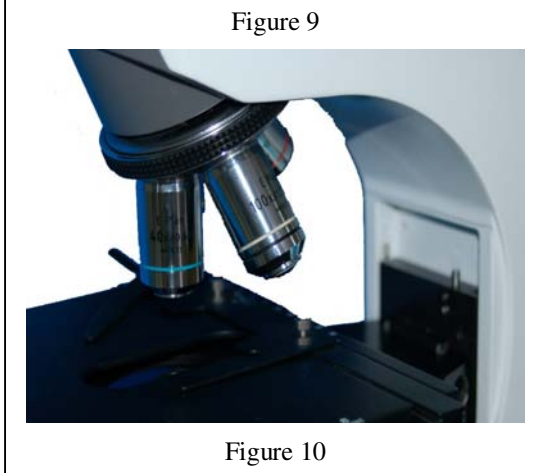
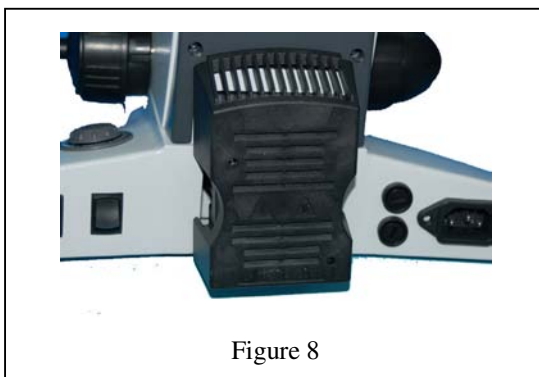
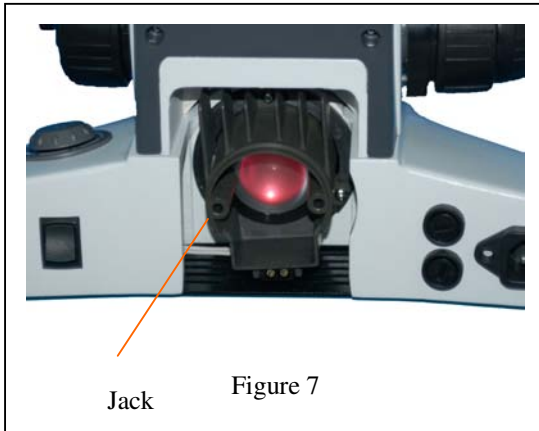

#### 2-2-4 Installing the Lamp House

Align the lamp house bolt (Fig. 6) with the jack on the back of the microscope (Fig.7), then gently push the lamp holder into the housing until they are completely against each other (Fig. 8).

#### 2-2-5 Installing the Objectives

1. Rotate the coarse focus knob until the mechanical stage is at its lowest position.
2. Install the lowest magnification objective into the nosepiece (Fig. 9). Then in a clock-wise direction rotate the nosepiece and install the objectives in succeeding higher magnification sequence (Fig. 10).

★ Inspect the objectives regularly for dust, dirt and oil. Clean the objectives according to the directions in the “Care and Maintenance” section.

★ Use the 10x objective to initially focus the image of your specimen.

★ To change objectives, rotate the nosepiece until you hear a “click” sound. This ensures the objective is centered in the optical light path.

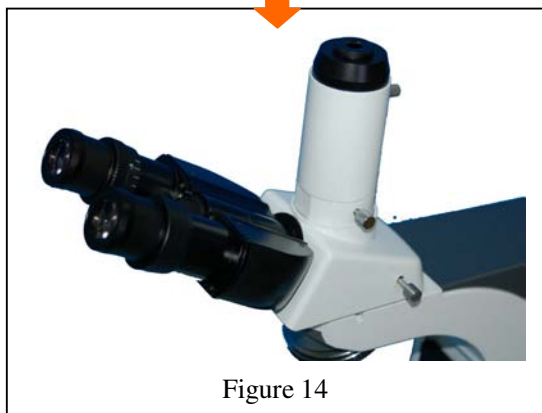

### 2-2-6 Installing the Eyepieces

Remove the protective caps from the eyepiece tubes. Insert the eyepieces into the eyepiece tubes (Fig. 11).

### 2-2-7 Installing the Video Port (optional)

Remove the protective cap from the vertical tube of the viewing head. Insert the video port (Fig. 12) into the trinocular viewing head (Fig. 13), then tighten the thumb screw.

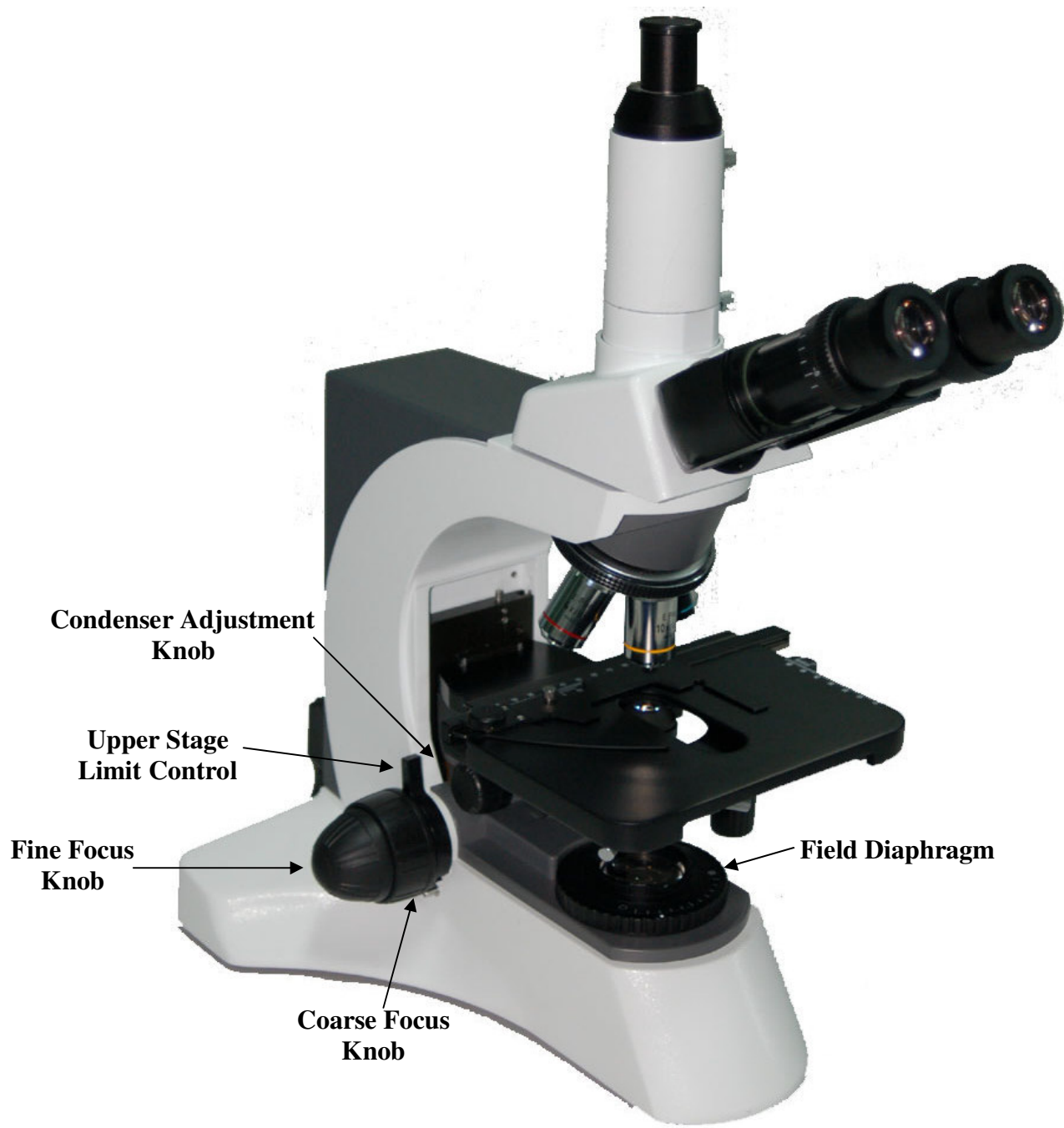

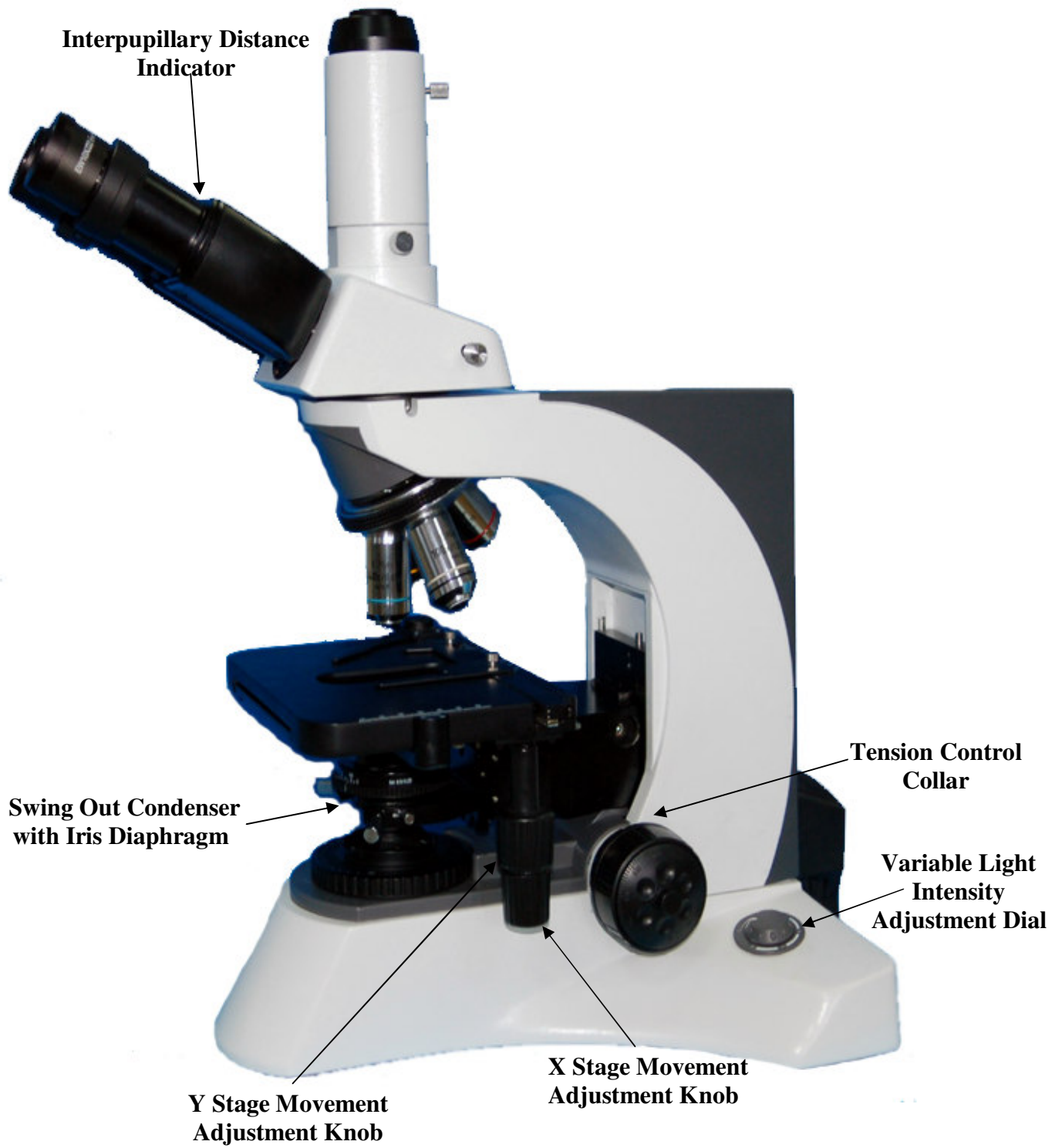

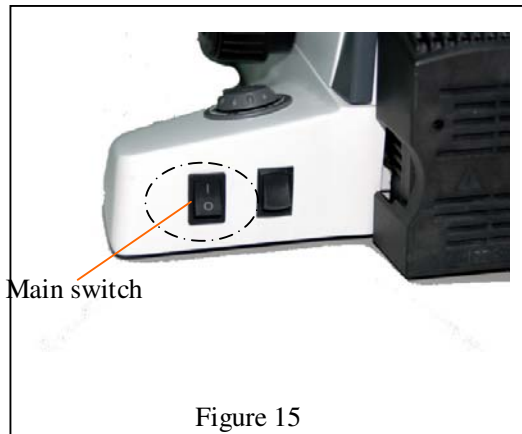

Figure 15

#### 4-1 Turning on the Lamp (Figure 15)

Connect the power cord, turn on the main switch (Figure 15) to the on position “-”

**NOTE: The switch adjacent to the main switch is non-functioning.**

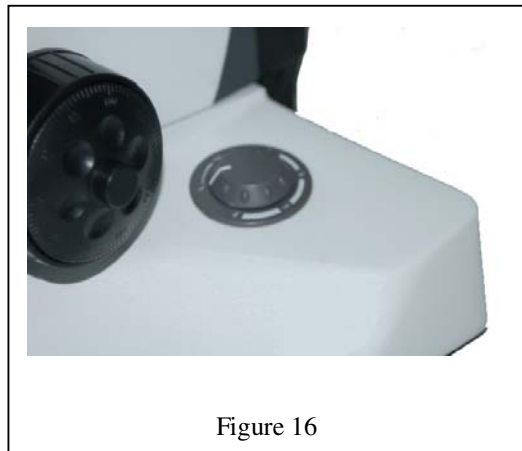

Figure 16

#### 4-2 Adjusting Illumination Intensity (Figure 16)

Adjust the illumination intensity by rotating the variable intensity dial.

✧ Use of the lamp at a lower intensity will prolong its life.



Tension Adjustment Collar

Figure 17

#### 4-3 Adjusting Tension Adjustment Collar (Figure 17)

★ The tightness of the tension adjustment collar is factory adjusted. If the collar loosens or the mechanical stage drops by itself, adjust the tension adjustment collar until the proper tension is restored.

**Use the black adjusting wrench supplied with the microscope to adjust the tension adjustment collar**





Figure 18

#### 4-4 Placement of Specimen (Fig. 18)

Place the slide on the mechanical stage. Use the slide holder to gently secure the slide. Turn the X and/or Y stage movement adjustment knobs to position the specimen.

★ Use caution when changing objectives. Do not allow an objective to touch a specimen slide. Doing so may damage the objective and specimen.

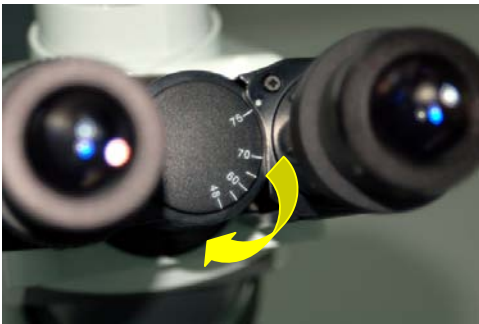

Figure 19

#### 4-5 Adjusting the Interpupillary Distance (Figure 19)

(Figure 19)

The interpupillary distance range: 48mm~75mm.

While observing with two eyes, hold the left and right eyetubes. Rotate the eyetubes around the central axis. Adjust the interpupillary distance until the left and right fields of view coincide completely with one image.



Figure 20

#### 4-6 Adjusting the Diopter (Figure 20)

1. Using the 10x objective and your right eye only, observe your specimen through the right eyepiece only and bring it into focus.
2. Then observe the specimen with your left eye only through the left eyepiece. If the specimen is not in focus, rotate the diopter collar (Fig.20) until a sharp image is obtained.

**The diopter range is  $\pm 5$**

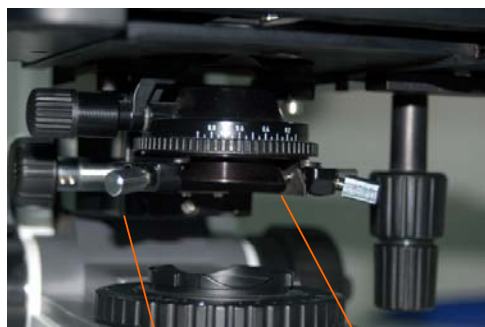



Figure 21



Figure 22



Swing Out Condenser

Aperture Diaphragm

Figure 23

#### **Adjusting the Aperture Diaphragm**

The aperture diaphragm is designed for the adjustment of the numerical aperture, not for brightness. Generally, reducing the diaphragm opening to 70-80% of the N.A. value of the respective objective will provide an image of acceptable quality. If you want to observe the image of the aperture diaphragm, remove one eyepiece and look through the tube. You will see a dark circle encroaching on the bottom of the tube

#### **4-7 Focusing (Figures 21 & 22)**

Push the light path selector lever (Figure 25) completely in. Lower the mechanical stage. With the 10x objective in position, raise the mechanical stage slowly using the coarse focusing knob until the specimen is in focus. Then rotate the fine focus until a sharp image is obtained. Do not allow the objective to touch the specimen.

#### **4-8 Adjusting the Swing Out Condenser (Figure 23)**

The center of the condenser and the light axis of the objective are coaxial. They have been factory adjusted and does not need to be adjusted . The upper limit of the condenser has also been adjusted.

Turn the condenser focus knob to adjust the condenser. Raise the condenser when using the higher magnification objectives, and lower the condenser when using lower magnification objectives.

**Swing out the condenser and away from the light path when using the 4x objective. Swing in the condenser and into the light path when using the 10x and higher magnification objectives.**



Figure 24



Figure 25

#### **4-9 Adjusting the Field Diaphragm (Fig. 24)**

The outer ring of the field diaphragm is used to adjust the area of field diaphragm.

1. Focus on your specimen with the 10x objective.
2. Close the field diaphragm to its smallest diameter.
3. Viewing through one eyepiece only, center the aperture diaphragm using the two centering screws.
4. Increase the size of the field diaphragm until the entire field of view is illuminated.

#### **4-10 Using the Light Path Selector Lever (Figure 25)**

##### **Using the Video Port (optional)**

Pull out the light path selector lever (Figure 25) to its full length.

On viewing heads marked 80/20, the specimen may be viewed through the eyepieces and on the video monitor. On viewing heads marked 100/0, the specimen may be viewed through the eyepieces or the video monitor.

**Main specifications**

Optical System	Infinity Optical System
Viewing Head	Compensation Free Trinocular Head, Inclined 30°; Diopter ±5 Interpupillary distance: 48-75mm
Eyepiece (Ocular)	Extra Wide Field EW10X/22, tubeΦ30 matched
Nosepiece	Reversed Quintuple Nosepiece
Objectives	Infinity Plan Achromat: 4x, 10x, 40x, 100x Oil
Focus System	Coaxial Coarse and Fine Focusing System Sensitivity and Graduation of Fine Focus: 0.001mm
Stage	Double plate mechanical stage; 185 x 142mm; movement range: 75 x 55mm
Koehler Illumination	Koehler illumination system, Aspheric collector, halogen lamp 6V30W
Condenser	Swing out condenser N.A. 0.9

**Configuration Table**

Viewing Head	Compensation Free Trinocular Head	●
Eyepiece	Extra Wide Field Eyepieces: EW10x/22	●
Objectives	Infinite Plan objectives: 4x, 10x, 40x, 100x Oil	●
	Infinite Plan Objective: 20x	○
Condenser	Swing out Condenser N.A. 0.9/0.25	●
Video Accessories		○
Video Mount	C-Mount 1x	○
	C-Mount 0.5x	○
Polarization		○
Turret Phase Contrast Condenser		○
Darkfield Condenser		○
Fluorescent Attachment		○
Temperature Control Device		○

Note: ● Standard    ○ Optional

**Objective Specifications**

Magnification	Numerical Value Aperture Diaphragm (N.A.)	Working Distance (mm)	Thickness of Cover Slip (mm)	Conjugate Distance (mm)	Objective Color Coding
4X	0.10	25.42	0.17	∞	Red
10X	0.25	11	0.17	∞	Yellow
40X	0.65	0.75	0.17	∞	Blue
100X	1.25	0.21	0.17	∞	Black and White

## TROUBLESHOOTING GUIDE

If a problem occurs during the course of use, please refer to the tables below

<b>OPTICAL</b>		
<b>Problem</b>	<b>Cause</b>	<b>Corrective Measure</b>
Darkness at the periphery or uneven brightness in the field of view	Revolving nosepiece not in click stop position	Revolve the nosepiece to click-stop position by swinging the objective correctly into the optical path
Dirt or dust on the viewfield	Dirt or dust on the lens - eyepiece, condenser, objective, collector lens or specimen	Clean the lens
Poor image quality	<p>No coverglass attached to the slide</p> <p>Coverglass is too thick or thin</p> <p>Slide may be upside down</p> <p>Immersion oil is on a dry objective (especially the 40xR)</p> <p>No immersion oil used with 100xR objective</p> <p>Air bubbles in immersion oil</p> <p>Condenser aperture is closed or open too much</p> <p>Condenser is positioned too low</p>	<p>Attach a 0.17mm coverglass</p> <p>Use a coverglass of the appropriate thickness (0.17mm)</p> <p>Turn slide over so the coverglass faces up</p> <p>Check the objectives, clean if necessary</p> <p>Use immersion oil</p> <p>Remove bubbles</p> <p>Open or close properly</p> <p>Position the condenser at the upper limit</p>
<b>IMAGE PROBLEMS</b>		
Image moves while focusing	<p>Specimen rises from stage surface</p> <p>Revolving nosepiece is not in the click-stop position</p>	<p>Secure the specimen in the slide holder</p> <p>Revolve the nosepiece to the click-stop position</p>
Image tinged yellow	Blue filter not used	Use daylight blue filter

<b>IMAGE PROBLEMS</b>		
<b>Problem</b>	<b>Cause</b>	<b>Corrective Measure</b>
Image tinged yellow	Lamp intensity is too low	Adjust the light intensity by rotating the intensity control dial
Image is too bright	Lamp intensity is too high	Adjust the light intensity by rotating the intensity control dial
Insufficient brightness	Lamp intensity is too low	Adjust the light intensity by rotating the intensity control dial
	Aperture diaphragm closed too far	Open to the proper setting
	Condenser position too low	Position the condenser at the upper limit
<b>MECHANICAL PROBLEMS</b>		
Image will not focus with high power objectives	Slide upside down	Turn the slide over so the cover glass faces up
	Cover glass is too thick	Use a 0.17mm cover glass
High power objective contacts slide when changed from low power objective	Slide upside down	Turn the slide over so the cover glass faces up
	Cover glass is too thick	Use a 0.17mm cover glass
	Diopter adjustment is not set properly	Readjust the diopter settings
Lamp does not light when switched on	No electrical power	Check power cord connection
	Lamp bulb burnt out	Replace bulb
	Fuse blown out	Replace fuse
Slippage of focus when using the coarse focusing knob	Tension adjustment is set too low	Increase the tension on the focusing knobs
Fine focus is ineffective	Tension adjustment is set too high	Loosen the tension on the focusing knobs

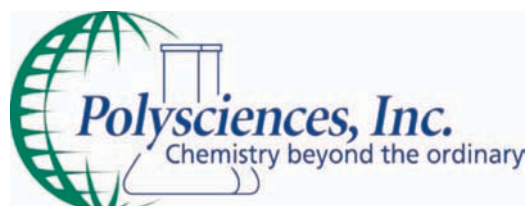

#### ORDERING INFORMATION

Cat. #	Description	
25097	3025 Upright Microscope with Dual Observation	1 unit

Order online anytime at [www.polysciences.com](http://www.polysciences.com)

#### Polysciences, Inc.

400 Valley Road  
Warrington, PA 18976

(800) 523-2575 / (215) 343-6484  
(800) 343-3291 / (215) 343-0214 fax  
[info@polysciences.com](mailto:info@polysciences.com)  
[www.polysciences.com](http://www.polysciences.com)

#### Polysciences Europe GmbH

Handelsstrasse 3  
D-69214 Eppelheim  
Germany

(49) 6221-765767  
(49) 6221-764620 fax  
[info@polysciences.de](mailto:info@polysciences.de)

#### Asia-Pacific Headquarters

Polysciences Asia Pacific, Inc.  
2F-1, 207 DunHua N. Rd.  
Taipei, Taiwan 10595

(886) 2 8712 0600  
(886) 2 8712 2677 fax  
[info@polysciences.tw](mailto:info@polysciences.tw)

Our catalog lists over 3,000 unique and specialty products that are used by histology professionals, lab technicians, pathologists, chemists and scientists worldwide. Visit [www.polysciences.com](http://www.polysciences.com) to learn more about our product lines.